

RE-NEET Exam. 2026 (21st June 2026)

Code-70 (Paper & Solution)

PHYSICS

Chapter : Matter Wave

Q.1 A photon and an electron, each of 20 eV energy, move in free space. The ratio of linear momentum of electron p_e to that of photon

$$p_{Ph}, \frac{p_e}{p_{Ph}} \text{ is :}$$

(Take speed of light = $3 \times 10^8 \text{ ms}^{-1}$, charge of electron = $-1.6 \times 10^{-19} \text{ C}$ and mass of electron = $9 \times 10^{-31} \text{ kg}$)

- (1) 275 (2) $\frac{2}{450}$
 (3) $\frac{1}{250}$ (4) 225

Ans. [4]

Sol. $E_e = E_{ph} = 20 \text{ eV}$

$$\Rightarrow p_e = \sqrt{2m_e E_e}, p_{ph} = \frac{E_{ph}}{c}$$

$$\Rightarrow \frac{p_e}{p_{ph}} = \sqrt{\frac{2m_e E_e}{E_{ph}}} \cdot c = \sqrt{\frac{2m_e}{E_{ph}}} \cdot c$$

$$\frac{p_e}{p_{ph}} = \sqrt{\frac{2 \times 9 \times 10^{-31}}{20 \times 1.6 \times 10^{-19}}} \times 3 \times 10^8$$

$$= \frac{3}{4} \times 10^{-6} \times 3 \times 10^8 = \frac{900}{4} = 225$$

Chapter : Fluid Mechanics

Q.2 Water flows in a streamline motion through a horizontal pipe of circular cross-section as shown in the figure. The pressure difference of water between P and Q is 15 Nm^{-2} . The area of cross-section at P and Q are 40 cm^2 and 20 cm^2 , respectively. The rate of flow of water through the pipe, in $\text{cm}^3 \text{ s}^{-1}$, is :

[Take density of water = 1000 kg m^{-3}]

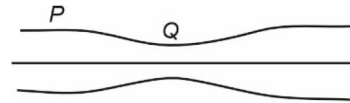

- (1) 400 (2) 100
 (3) 200 (4) 300

Ans. [1]

Sol.

$$A_P V_P = A_Q V_Q$$

$$40 V_P = 20 V_Q, V_Q = 2 V_P$$

Using Bernoulli's equation:

$$P_P - P_Q = \frac{1}{2} \rho (V_Q^2 - V_P^2)$$

$$15 = \frac{1}{2} \times 10^3 (4V_P^2 - V_P^2)$$

$$V_P = \sqrt{\frac{15}{1500}} = 0.1 \text{ m/s}$$

$$V_Q = 0.2 \text{ m/s}$$

$$\text{Rate} = A_P V_P = 40 \times 10^{-4} \times 10^{-1} \text{ m}^3/\text{s}$$

$$= 4 \times 10^{-4} \text{ m}^3/\text{s}$$

$$= 4 \times 10^{-4} \times 10^6 \text{ cm}^3/\text{s}$$

$$= 400 \text{ cm}^3/\text{s}$$

Chapter : Rotational motion

Q.3 A thin horizontal disc is rotating about a vertical axis passing through its fixed centre O. Its angular momentum is L_A and L_B computed about points A and B, respectively, with $OB = 2 \times OA$. The value of $\frac{L_A}{L_B}$ is :

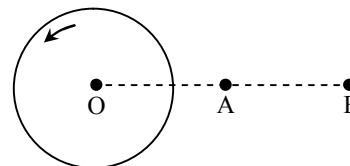

- (1) 2 (2) $\frac{1}{4}$ (3) $\frac{1}{2}$ (4) 1

Ans. [4]

Sol. $\vec{L} = \vec{r} \times \vec{P} + I_{cm} \vec{\omega}$
 $\vec{P} = 0$ for both axis
 So $\vec{L}_A = \vec{L}_B = I_{cm} \vec{\omega}$
 $\frac{\vec{L}_A}{\vec{L}_B} = 1$

Chapter : Electro Magnetic Induction (E.M.I.)

Q.4 Consider a long solenoid of length ℓ and radius r . If n is the number of turns per unit length and μ_0 is the permeability of free space, the inductance of the solenoid is :

- (1) $2\mu_0\pi n^2 r^2 \ell$ (2) $\mu_0\pi n^2 r^2 \ell$
 (3) $\mu_0 n^2 r^2 \ell$ (4) $(\mu_0 / 2\pi) n^2 r^2 \ell$

Ans. [2]

Sol. Self-inductance of solenoid

$$L = \frac{L\phi}{i}$$

$$L = \frac{NBA}{i}$$

$$L = \frac{N\mu_0 niA}{i} \quad \left[n = \frac{N}{\ell} \right]$$

$$L = N\mu_0 nA$$

$$L = \left(\frac{N}{\ell} \right) \mu_0 nA\ell$$

$$L = \mu_0 n^2 A\ell$$

$$L = \mu_0 n^2 \pi r^2 \ell \quad [\because A = \pi r^2]$$

Chapter : Thermal Expansion

Q.5 The temperature of a metallic sphere of radius R is increased by a small amount of ΔT . If the linear coefficient of thermal expansion of the metal is α , the approximate increase in the volume of the sphere is :

- (1) $6\pi R^3 \alpha \Delta T$ (2) $2\pi R^3 \alpha \Delta T$
 (3) $3\pi R^3 \alpha \Delta T$ (4) $4\pi R^3 \alpha \Delta T$

Ans. [4]

Sol. For the metallic sphere, $\frac{\Delta R}{R} = \alpha \Delta T$

Volume of the sphere, $V = \frac{4}{3} \pi R^3$

$$\therefore \frac{\Delta V}{V} = 3 \frac{\Delta R}{R}$$

Increase in volume

$$= \Delta V = 3 \left(\frac{\Delta R}{R} \right) \left(\frac{4}{3} \pi R^3 \right) = 4\pi R^3 \alpha \Delta T$$

Chapter : Current Electricity

Q.6 Consider two circuits, (A) and (B), each having two resistors. One of them has a positive temperature coefficient of resistance, $+\alpha$, while the other one has a negative temperature of coefficient, $-\alpha$, as shown in the figure. The current through three circuits are denoted by I_A and I_B . At initial temperature, the resistance of the two resistors is R_0 . As the temperature is increased, the correct option that describes the variation of current in these circuits is :

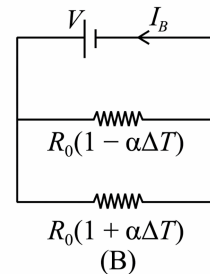
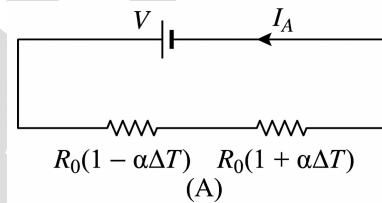

- (1) both I_A and I_B remain constant
 (2) I_A remains constant while I_B increases
 (3) I_A decreases while I_B increases
 (4) I_A increases while I_B decreases

Ans. [2]

Sol. **Figure A**

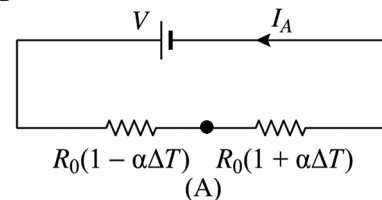

$$R_{eq} = R_0 [1 - \alpha \Delta T] + R_0 [1 + \alpha \Delta T]$$

$$= 2R_0 = \text{constant}$$

$$\therefore I_A = \frac{V}{2R_0} \rightarrow \text{Constant}$$

Figure B

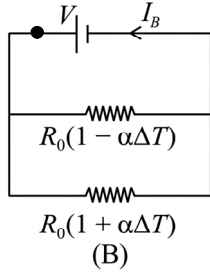

$$R_{eq} = \frac{R_0(1 + \alpha\Delta T)R_0(1 - \alpha\Delta T)}{R_0(1 + \alpha\Delta T) + R_0(1 - \alpha\Delta T)}$$

$$R_{eq} = \frac{R_0(1 - \alpha^2(\Delta T)^2)}{2R_0}$$

R_{eq} Will decrease with rise in temperature

$$\therefore I_B = \frac{V_0}{R_{eq}} \text{ increase with rise in temperature}$$

Chapter : Photoelectric Effect

Q.7 A beam of light falls on a metal surface such that photo-electrons are generated. If power of the light source starts to decrease linearly with time t , then variation of the photocurrent I and magnitude of the stopping potential $|V|$ with time is best represented by :

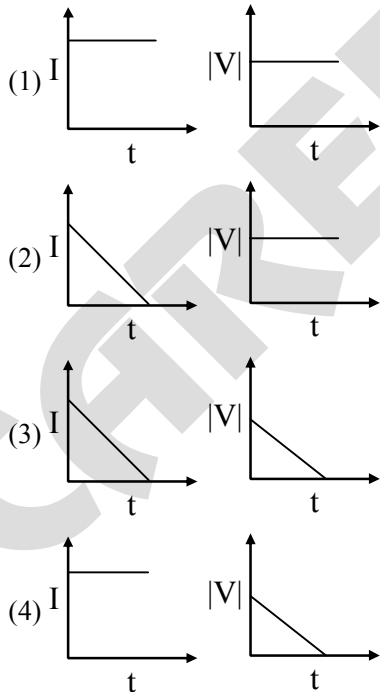

Ans. [2]

Sol. Power of source is decreasing that means number of photon is decreasing linearly with time and source is same so, energy of photon is same.

Power $(P) \propto nE$,

$P \propto n$ (number of photons per second)

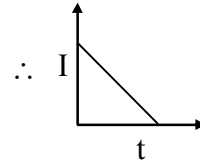

and energy of photon is constant.

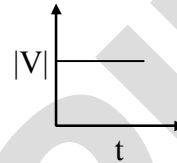

Chapter : Semiconductor & Electronic Devices

Q.8 An ideal Zener diode with breakdown voltage of $-3V$ is reverse biased with a negative input voltage $V_i = -5V$. The magnitude of voltage difference between points B and A is :

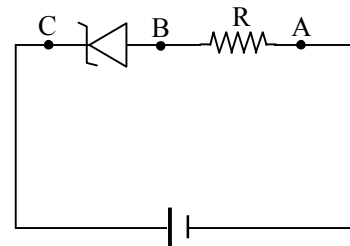

- (1) 0 V
- (2) 3 V
- (3) 2 V
- (4) 1 V

Ans. [3]
Sol.

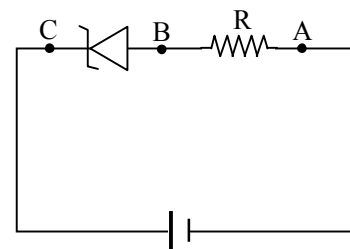

$$|V_{input}| (5V) > |V_{zener}| (3V)$$

$$V_{zener} = 3V$$

$$V_{Total} = 5V$$

$$\therefore |V_{BA}| = (5 - 3) = 2V$$

Chapter : Electro Magnetic Induction (E.M.I.)

Q.12 Two identical inductors are connected in two different configurations P and Q, where a time varying current $I(t)$ is flowing, as shown in the figure. The induced emf between points a and b for configuration P is E_P and that for configuration Q is E_Q . The ratio E_P/E_Q is :
[Neglect the effect of mutual inductance.]

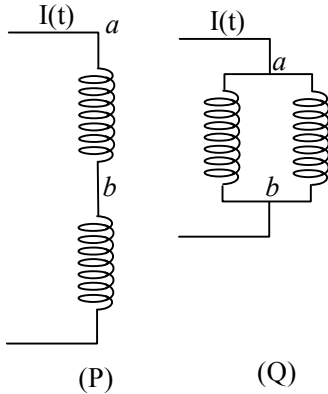

- (1) 2 (2) 1/4 (3) 1/2 (4) 1

Ans. [1]
Sol.

In figure (P)

$$E_P = E_{ab} = - \frac{L dI(t)}{dt} \quad \dots(i)$$

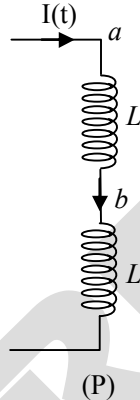

In figure (Q)

$$E_Q = E_{ab} = - \frac{L}{2} \frac{dI(t)}{dt} \quad \dots(2)$$

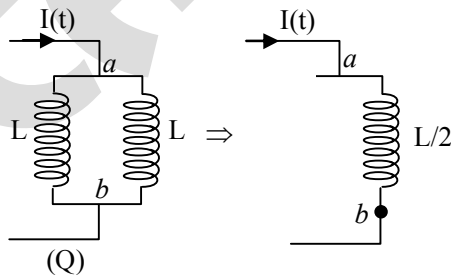

$$\Rightarrow \frac{E_P}{E_Q} = \frac{2}{1}$$

Chapter : Capacitance

Q.13 Three identical capacitors P, Q and S, each of the capacitance C , are connected to a battery of voltage V , as shown in the figure. If the energy stored in the capacitor P and total energy stored in the system are U_P and U_T , respectively, then the ratio $\frac{U_P}{U_T}$ is :

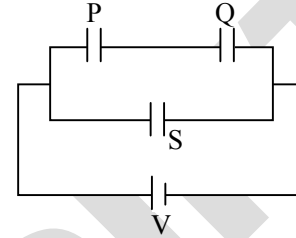

- (1) 1/6 (2) 2/3 (3) 1/3 (4) 1/2

Ans. [1]

Sol. $C_P = C_Q = C_S = C$

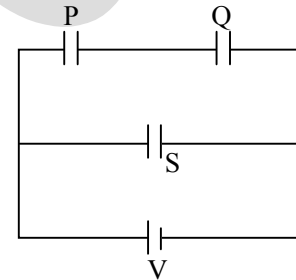

$$U_P = \frac{1}{2} C \left(\frac{V}{2} \right)^2 = \frac{1}{2} \frac{CV^2}{4} = \frac{CV^2}{8}$$

$$U_T = U_P + U_Q + U_S = \frac{1}{2} C \left(\frac{V}{2} \right)^2 + \frac{1}{2} C \left(\frac{V}{2} \right)^2 + \frac{1}{2} CV^2$$

$$= \frac{CV^2}{8} + \frac{CV^2}{8} + \frac{1}{2} CV^2 = \frac{6}{8} CV^2 = \frac{3}{4} CV^2$$

$$\frac{U_P}{U_T} = \frac{CV^2}{8 \times \frac{3}{4} CV^2} = \frac{1}{6}$$

Chapter : Electro Magnetic Induction (E.M.I.)

Q.14 A conducting loop of finite resistance lies on the x - y plane. There is a constant magnetic field in the z direction. The area of the loop varies with time t , as $A = A_0(1 + \sin t)$ in appropriate units. The figure that correctly indicates the qualitative behavior of the power P dissipated in the loop as a function of time is:

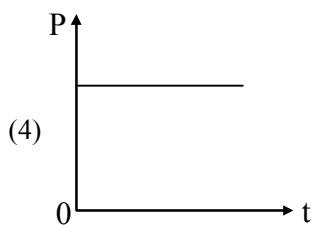
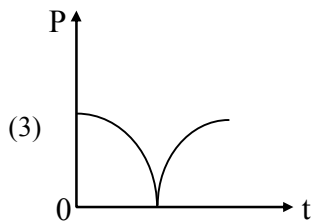
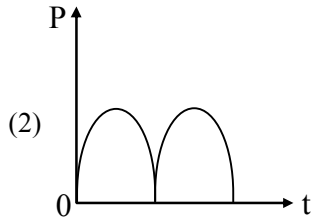
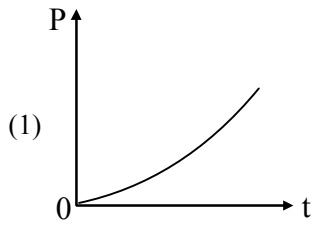

Ans. [3]

Sol. $A = A_0 (1 + \sin t)$

$$\phi = BA = BA_0 (1 + \sin t)$$

$$\epsilon = - \frac{d\phi}{dt} = -BA_0 \cos t$$

$$I_{\text{induced}} = \frac{\epsilon_{\text{ind}}}{R} = \frac{BA_0}{R} \cos t$$

$$\text{Power} = P = I^2 R = \frac{B^2 A_0^2 \cos^2 t}{R}$$

$$P \propto \cos^2 t$$

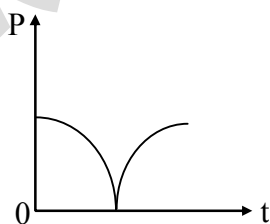

Chapter : Thermodynamics

Q.15 In an adiabatic expansion, the temperature of one mole of an ideal monatomic gas ($\gamma = 5/3$) decreases from 60 K to 50 K. The work done by the gas in the process is :

[Take the universal gas constant as

$$R = 8.3 \text{ J mol}^{-1} \text{ K}^{-1}]$$

(1) 166 J

(2) 41.5 J

(3) 83 J

(4) 124.5 J

Ans. [4]

Sol. Work done in adiabatic process

$$W = \frac{nR\Delta T}{1-\gamma}$$

$$\Delta T = -10 \text{ K}$$

$$W = \frac{1 \times 8.3 \times (-10)}{1 - \frac{5}{3}}$$

$$W = \frac{83 \times 3}{2}$$

$$W = 124.5 \text{ J}$$

Chapter : Motion in one Dimension

Q.16 Consider a particle moving along a straight line, whose position as a function of time is given by $s(t) = \alpha t^2 - \beta t + \gamma$, where $\alpha = 1 \text{ ms}^{-2}$, $\beta = 6 \text{ ms}^{-1}$ and $\gamma = 5 \text{ m}$. The average speed of the particle, in ms^{-1} , from $t = 0$ to $t = 6 \text{ s}$ is :

(1) 0

(2) 12

(3) 6

(4) 3

Ans. [4]

Sol. Position (s)

$$S = \alpha t^2 - \beta t + \gamma$$

$$S = t^2 - 6t + 5$$

Velocity (v)

$$v = \frac{ds}{dt} = 2t - 6$$

$$\text{When } v = 0 = 2t - 6$$

$$t = 3 \text{ s}$$

From (ii), graph between (v/t)

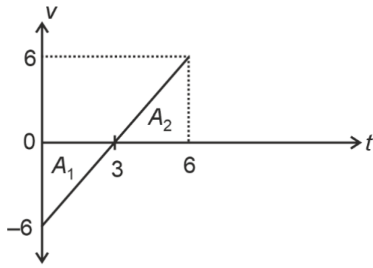

For distance

$$d = (+A_1) + A_2$$

$$d = \frac{1}{2} \times 3 \times 6 + \frac{1}{2} \times 3 \times 6$$

$$d = 3 \times 6 = 18$$

$$\text{Average speed } (v_{\text{avg}}) = \frac{\text{Distance}}{\text{Time}}$$

$$= \frac{d}{\Delta t} = \frac{18}{6} = 3 \text{ ms}^{-1}$$

Chapter : Electro Magnetic Wave (E.M.W.)

Q.17 The following table presents the part of the electromagnetic spectrum and their corresponding major applications.

Part of the electromagnetic spectrum	Applications
(P) Microwave	(I) For purifying the water
(Q) UV rays	(II) For warming the food
(R) Gamma rays	(III) For AM and FM communication
(S) Radio wave	(IV) For treating the cancer cells

The correct option is

- (1) P-II, Q-IV, R-III, S-I
- (2) P-I, Q-II, R-III, S-IV
- (3) P-I, Q-IV, R-II, S-III
- (4) P-II, Q-I, R-IV, S-III

Ans. [4]

Sol.

Part of the electromagnetic spectrum	Applications
Microwave	For warming the food
UV rays	For purifying the water
Gamma rays	For treating the cancer cells
Radio wave	For AM and FM communication

Chapter : Kinetic Theory of Gases (K.T.G.)

Q.18 An ideal gas is made of polyatomic molecules. Each of the molecules has three translational, three rotational and f number of vibrational modes. If the ratio of heat capacities C_p/C_v of the gas is $8/7$, then the value of f is

- (1) 1
- (2) 4
- (3) 3
- (4) 2

Ans. [2]

Sol. The total internal energy for one mole of gas, U

$$= \left(\frac{3}{2} k_B T + \frac{3}{2} k_B T + f k_B T \right) N_A$$

$$= (3 + f) k_B T N_A = (3 + f) R$$

$$\therefore C_V = \frac{dU}{dT} = (3 + f) R$$

$$\Rightarrow \frac{C_p}{C_v} = \frac{4 + f}{3 + f} = \frac{8}{7} \text{ (given)}$$

$$\Rightarrow f = 4$$

Chapter : Electrostatics

Q.19 A unit positive point charge is taken slowly through an infinitesimally thin tube that is inside a charged dielectric sphere of radius R , having uniform positive charge density ρ , as shown in the figure. The initial and final positions of the charge are marked by A and B at distances $2R$ and $3R$ respectively, from the centre of the sphere. In this process, the magnitude of the total work done on the point charge is value of n is $\frac{\rho R^2}{n \epsilon_0}$. The value of n is :

(ϵ_0 is the permittivity of vacuum)

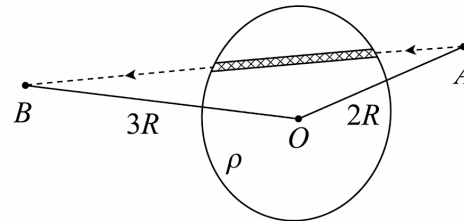

- (1) 18
- (2) 2
- (3) 6
- (4) 9

Ans. [1]

Sol. Work done $W = q(V_B - V_A)$

$$= q \left[\frac{KQ}{3R} - \frac{KQ}{2R} \right] = \frac{Kq}{R} \left[\frac{-Q}{6} \right]$$

$$|W| = \frac{KqQ}{6R} = \frac{1}{4\pi\epsilon_0} \times \frac{q}{R} \times \frac{1}{6} \times \rho \times \frac{4}{3} \pi R^3$$

$$|W| = \frac{\rho R^2}{18\epsilon_0} \quad [\because q = 1]$$

$$\therefore n = 18$$

Chapter : Magnetic Effect of Current

Q.20 A current I_0 flows through a metallic circular loop of radius r as shown in the figure. Resistance of the segment ABC is half that of ADC. Magnitude of magnetic field at the center O of the loop is :

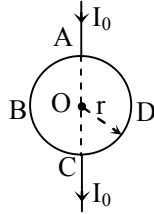

- (1) $\frac{\mu_0 I_0}{2\pi r}$ (2) $\frac{\mu_0 I_0}{12r}$
 (3) $\frac{\mu_0 I_0}{4r}$ (4) $\frac{\mu_0 I_0}{2r}$

Ans. [2]

Sol.

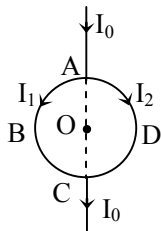

$$I_1 + I_2 = I_0$$

$$2I_2 + I_2 = I_0$$

$$I_1 R_{ABC} = I_2 R_{ADC}$$

$$I_1 + I_2 = I_0$$

$$I_1 \frac{R}{2} = I_2 R$$

$$\frac{I_1}{2} = I_2$$

$$I_2 = \frac{I_0}{3}$$

$$I_1 = \frac{2I_0}{3}$$

$$\vec{B}_0 = \vec{B}_1 + \vec{B}_2$$

$$= \frac{\mu_0 I_1 (\bullet)}{4r} + \frac{\mu_0 I_2 (\times)}{4r}$$

$$= \frac{\mu_0 2I_0}{4r \times 3} - \frac{\mu_0 I_0}{4r \times 3} = \frac{\mu_0 I_0}{12r}$$

Chapter : Conservation Laws

Q.21 Bob B of mass m at rest is hanging vertically from the ceiling via a massless string of length 10 m , as shown in the figure. Point mass A of mass m travelling horizontally with speed 10 ms^{-1} , hits bob B elastically. The bob B rises h meter after the collision. Taking the acceleration due to gravity $g = 10\text{ ms}^{-2}$ and neglecting the size of the bob, the value of h is:

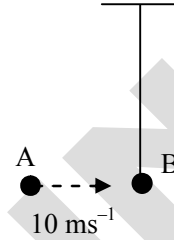

- (1) 2.5 (2) 8
 (3) 7 (4) 5

Ans. [4]
Sol.

- To reach the horizontal position, velocity of bob should be $= 10\sqrt{2}\text{ m/s}$
 - Velocity of bob and point mass will be interchanged after elastic collision
- By conservation of energy

$$mgh = \frac{1}{2}mv^2$$

$$h = \frac{v^2}{2g}$$

$$h = \frac{(10)^2}{2 \times 10}$$

$$h = 5\text{ m}$$

Chapter : Electro Magnetic Wave (E.M.W.)

Q.22 An electromagnetic wave travelling in a lossless dielectric medium having a dielectric constant, $\epsilon_r = 9$, has the electric field, $E_x = E_0 \sin(kz - 2\pi \times 10^6 t)\text{ Vm}^{-1}$ where E_0 is the amplitude and k is the wave vector. Among the following options, the **incorrect** choice is :

- (1) The direction of propagation of the electromagnetic wave is along $+z$
- (2) The speed of the electromagnetic wave inside the medium is 10^8 ms^{-1}
- (3) The wavelength of the electromagnetic wave inside the medium is 300 m
- (4) The magnetic field is given by the relation

$$B_y = \frac{B_0}{v} \sin[kz - 2\pi \times 10^6 t]$$

where v is the speed of the electromagnetic wave inside the medium

Ans. [3]

Sol. $\Rightarrow E_x = E_0 \sin(kz - 2\pi \times 10^6 t) = E_0 \sin(kz - \omega t)$
 \Rightarrow Direction of propagation of wave is along +z axis.

\Rightarrow Speed of wave in medium

$$v_m = \frac{v_0}{\sqrt{\epsilon_r}} = \frac{c}{\sqrt{9}} = \frac{3 \times 10^8}{3}$$

$$v_m = 10^8 \text{ m/s}$$

\Rightarrow Wavelength in medium = λ_m

$$\lambda_m = \frac{v_m}{f_0} = \frac{10^8}{\frac{2\pi \times 10^6}{2\pi}} = 100 \text{ m} [\because f_0 = \text{constant}]$$

\therefore Wavelength of the electromagnetic wave inside the medium is 100 m.

Note :- Among the options, in the expression

$B_y = \frac{B_0}{v} \sin(kz - 2\pi \times 10^6 t)$. B_0 should be replaced by E_0

Chapter : Work, Power, Energy

Q.23 A particle of mass M moves along a horizontal x axis from $x = 0$ to $x = L$. The coefficient of kinetic friction varies as a function of x as $\mu_k(x) = \mu_0 - \alpha x$, where μ_0 , α are constants of appropriate dimensions, so that $\mu_k(L) = 0$. The total work done by the frictional force during the motion is $n\mu_0 MgL$, where g is the acceleration due to gravity. The value of n is :

- (1) 1/2 (2) 3
 (3) 1 (4) 1/3

Ans. [1]

Sol. Sol. Given $\mu_k(x) = \mu_0 - \alpha x$ and $\mu_k(L) = 0$
 $= \mu_0 - \alpha L \Rightarrow \mu_0 = \alpha L$

Magnitude of work done by frictional force,

$$W_f = \int dW_f$$

where $dW_f = f_k dx = \mu_k Mg dx = (\mu_0 - \alpha x) Mg dx$

$$\therefore W_f = \int_0^L \mu_0 Mg dx - \int_0^L \alpha x Mg dx$$

$$= \mu_0 Mg [x]_0^L - \alpha Mg \left[\frac{x^2}{2} \right]_0^L$$

$$\Rightarrow n\mu_0 MgL = \mu_0 MgL - \left(\frac{\mu_0}{L} \right) Mg \left(\frac{L^2}{2} \right) = \frac{\mu_0 MgL}{2}$$

$$\Rightarrow n = \frac{1}{2}$$

Chapter : Refraction at Plain surface

Q.24 Consider three media P, Q and R with refractive indices 1, 1.25, and 1.5, respectively. The medium Q having a thickness of 5 cm is placed between extended media P and R as shown in the figure. An object O is placed at the center of medium Q. If viewed from medium P near the normal direction, the apparent depth of O is h_1 . For similar observation from medium R, the apparent depth is h_2 . The value of $|h_1 - h_2|$, in cm, is :

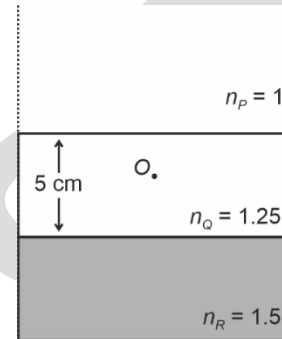

- (1) 3 (2) 0
 (3) 1 (4) 2

Ans. [3]

Sol. (i) When object O is viewed from medium P,

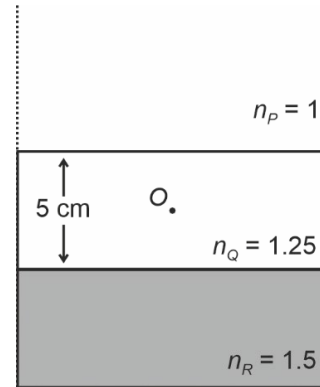

$$\text{Apparent depth } h_1 = \frac{h_{\text{real}}}{\mu} = \frac{2.5}{1.25} = 2 \text{ cm}$$

(ii) When object O is viewed from medium R,

$$\text{Apparent depth } h_2 = \mu_R \times 2.5$$

$$= 2.5 \times \frac{1.5}{1.25} = 3 \text{ cm}$$

$$\therefore |h_1 - h_2| = 1 \text{ cm}$$

Chapter : Electrostatics

Q.25 Consider a fixed uniformly charged insulating sphere with radius R and total charge $+Q$. A point charge $-q$ ($q \ll Q$) with mass m is released from rest at a distance of $3R$ from the centre of charged sphere. When the point charge reaches the sphere, its speed is :

(ϵ_0 is the permittivity of vacuum, neglect gravitational forces).

(1) $\sqrt{\frac{Qq}{4\pi\epsilon_0 mR}}$ (2) $\sqrt{\frac{3Qq}{4\pi\epsilon_0 mR}}$

(3) $\sqrt{\frac{2Qq}{3\pi\epsilon_0 mR}}$ (4) $\sqrt{\frac{Qq}{3\pi\epsilon_0 mR}}$

Ans. [4]
Sol.

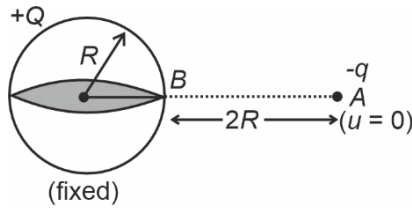

$$\Rightarrow \frac{1}{2}mv^2 = q \left[\frac{kQ}{R} - \frac{kQ}{3R} \right]$$

$$\Rightarrow \frac{1}{2}mv^2 = \frac{kQq}{R} \left[\frac{2}{3} \right]$$

$$\Rightarrow v^2 = \frac{kQq \times 4}{3Rm} = \frac{1 \times Qq \times 4}{4\pi\epsilon_0 \times 3Rm} = \frac{qQ}{3\pi\epsilon_0 Rm}$$

$$v = \sqrt{\frac{Qq}{3\pi\epsilon_0 mR}}$$

Chapter : Circular Motion

Q.26 A car travels on a circular race track of radius 50 m, which is banked at an angle θ . If the car travels at a speed 10 ms^{-1} , then the wear and tear on its tyres is minimum. Taking the acceleration due to gravity to be 10 ms^{-2} , the value of θ is :

(1) $\tan^{-1}(2\sqrt{3})$ (2) $\tan^{-1}\left(\frac{1}{5}\right)$

(3) $\tan^{-1}\left(\frac{2}{5}\right)$ (4) $\tan^{-1}\left(\frac{\sqrt{3}}{2}\right)$

Ans. [2]

Sol. $\tan \theta = \frac{v^2}{rg} = \frac{10 \times 10}{50 \times 10} = \frac{1}{5}$

$\theta = \tan^{-1}\left(\frac{1}{5}\right)$

Chapter : Circular Motion

Q.27 A frictionless circular wire of unit radius is fixed on the horizontal plane. Two point particles of unit mass start moving simultaneously from point $A \left(\theta = \frac{\pi}{2} \right)$ with identical uniform angular speeds in opposite directions, and meet again at point $B \left(\theta = -\frac{\pi}{2} \right)$. During this time, which of the following figures schematically represent the magnitude of the total linear momentum P of the system, as a function of θ ?

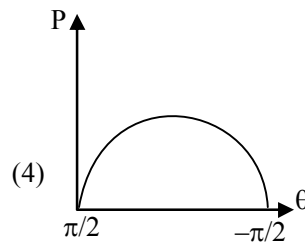
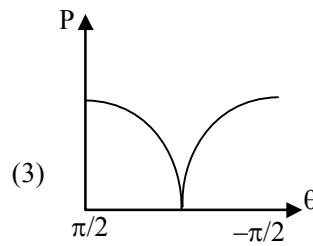
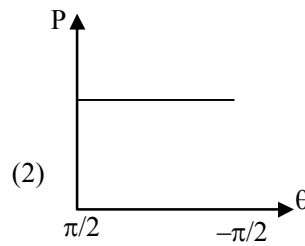
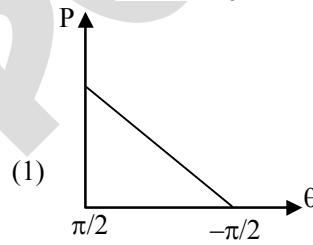
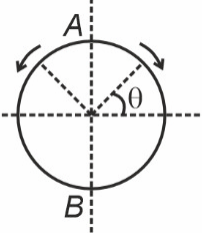

Ans. [4]
Sol.

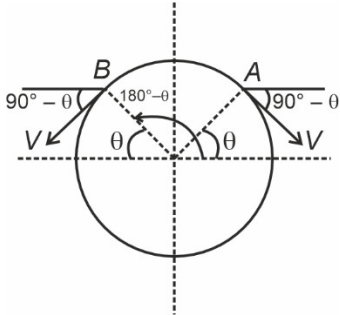

$$\vec{P}_{net} = -mv \sin \theta \hat{i} - mv \cos \theta \hat{j} + mv \sin \theta \hat{i} - mv \cos \theta \hat{j}$$

$$\vec{P}_{net} = -2mv \cos \theta \hat{j}$$

at $\theta = \frac{\pi}{2}$, $\vec{P}_{net} = 0$, at $\theta = -\frac{\pi}{2}$, $\vec{P}_{net} = 0$

So most appropriate graph is

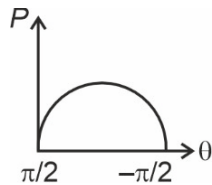

Chapter : Semiconductor & Electronic Devices

Q.28 Three identical p-n junction diodes D_1 , D_2 and D_3 are connected across a battery as shown in the figure. If the width of the depletion regions of D_1 , D_2 and D_3 are W_1 , W_2 and W_3 , respectively, then the correct option is :

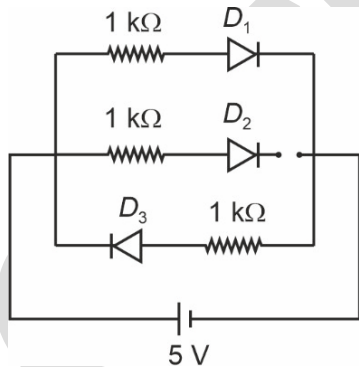

- (1) $W_2 > W_1 = W_3$
- (2) $W_1 > W_2 = W_3$
- (3) $W_3 = W_1 > W_2$
- (4) $W_3 > W_2 > W_1$

Ans. [4]
Sol.

D_1 is forward biased
Depletion region of forward bias (W_1) will be minimum
 D_3 is reverse biased
Depletion region of reverse bias (W_3) will be maximum

D_2 is unbiased
Depletion region (W_2) will be between (W_1) and (W_3)
Correct relation will be given as
 $W_3 > W_2 > W_1$

Chapter : Refraction at curved surface

Q.29 The lens combination as shown in the figure, consists of two lenses, L_1 and L_2 , of the focal lengths + 10cm and -10 cm respectively. The position of the image formed is :

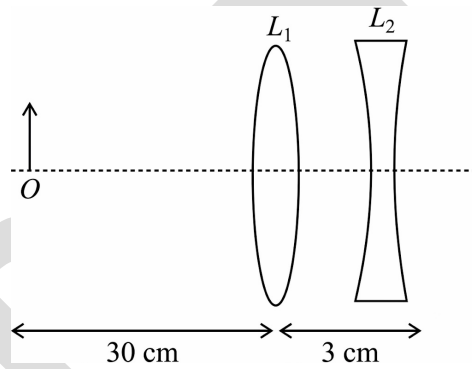

- (1) 60 cm to the right of the concave lens
- (2) 20 cm to the left of the concave lens
- (3) 60 cm to the left of the concave lens
- (4) 30 cm to the right of the concave lens

Ans. [3]
Sol.

For convex lens L_1 : $u = -30$ cm and $f = +10$ cm

$$\text{Using } \frac{1}{v} - \frac{1}{u} = \frac{1}{f} \Rightarrow \frac{1}{v} + \frac{1}{30} = \frac{1}{10}$$

$$\Rightarrow \frac{1}{v} = \frac{1}{10} - \frac{1}{30} = \frac{2}{30}$$

$$\therefore v = +\frac{30}{2} = +15 \text{ cm}$$

For concave lens L_2 : $u' = +12$ cm and $f' = -10$ cm

$$\text{Using } \frac{1}{v'} - \frac{1}{u'} = \frac{1}{f'} \Rightarrow \frac{1}{v'} - \frac{1}{12} = \frac{-1}{10}$$

$$\Rightarrow \frac{1}{v'} - \frac{1}{12} - \frac{1}{10} = \frac{-1}{60}$$

$$\therefore v' = -60 \text{ cm}$$

\therefore Final image formed at 60 cm to the left to concave lens.

Chapter : Rotational motion

Q.30 A solid sphere A of radius R and mass M is attached at a point to a smaller solid sphere B of radius $r < R$ and mass $m < M$. Assume that the line joining their centres lies along the horizontal. The moment of inertia of the system calculated about a vertical axis passing through the centre of A is I_A and that calculated about a vertical axis passing through the centre of B is I_B . The difference $I_A - I_B$ is :

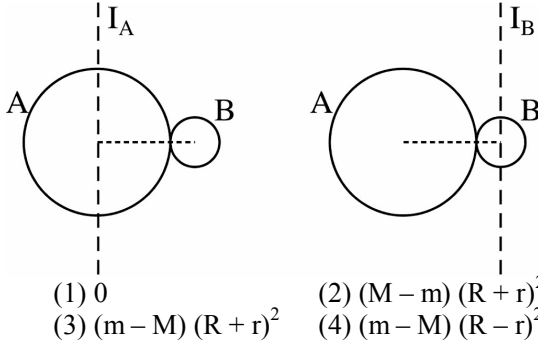

- (1) 0 (2) $(M - m)(R + r)^2$
 (3) $(m - M)(R + r)^2$ (4) $(m - M)(R - r)^2$

Ans. [3]

Sol. Using $I_C = \frac{2}{5}mR^2$ and Parallel axis theorem, moment of inertia of system

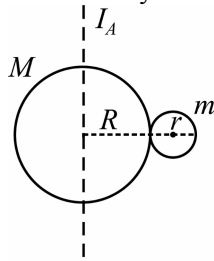

$$I_A = \frac{2}{5}MR^2 + \frac{2}{5}mr^2 + m(R + r)^2 \quad \dots (1)$$

Similarly,

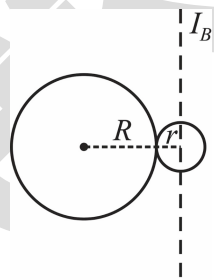

$$I_B = \frac{2}{5}MR^2 + M(R + r)^2 + \frac{2}{5}mr^2 \quad \dots (2)$$

Now, subtracting (1) and (2)

$$I_A - I_B = (m - M)(R + r)^2$$

Chapter : Atomic Structure

Q.31 Consider that an electron is revolving in an excited state of hydrogen atom with velocity $\sqrt{25.6} \times 10^5 \text{ ms}^{-1}$. The radius of the orbit is $x \times 10^{-9} \text{ m}$. The value of x is
 [Take the mass of electron to be $9 \times 10^{-31} \text{ kg}$, charge of electron = $-1.6 \times 10^{-19} \text{ C}$ and $\frac{1}{4\pi\epsilon_0} = 9 \times 10^9 \text{ N m}^2 \text{ C}^{-2}$]

- (1) 1 (2) 4 (3) 3 (4) 2

Ans. [1]

Sol. $F_C = \frac{mv^2}{r}$
 $\Rightarrow \frac{kq_1q_2}{r^2} = \frac{mv^2}{r}$
 $\Rightarrow \frac{ke^2}{r} = mv^2$
 $\Rightarrow r = \frac{ke^2}{mv^2} = \frac{9 \times 10^9 \times (1.6 \times 10^{-19})^2}{9 \times 10^{-31} \times 25.6 \times 10^{10}}$
 $\Rightarrow r = \frac{2.56 \times 10^9 \times 10^{-38}}{25.6 \times 10^{-21}}$
 $r = 1 \times 10^{-9} \text{ m}$
 $\therefore x = 1$

Chapter : Kinetic Theory of Gases (K.T.G.)

Q.32 The mean free path of molecules in an ideal gas A is half that of another ideal gas B. The diameter of the spherical molecules of gas A is twice the diameter of the molecules of B. If number densities of the gases A and B are n_A and n_B , respectively, then the correct option is :

- (1) $n_A = \frac{1}{2}n_B$ (2) $n_A = n_B$
 (3) $n_A = 2n_B$ (4) $n_A = \frac{1}{4}n_B$

Ans. [1]

Sol. $\lambda_A = \frac{1}{2}\lambda_B$
 $\lambda = \frac{1}{\sqrt{2}\pi d^2 n}$
 $d_A = 2d_B$
 $\lambda_A = \frac{1}{\sqrt{2}\pi d_A^2 n_A}$

$$\lambda_B = \frac{1}{\sqrt{2} \pi d_B^2 n_B}$$

$$\frac{\lambda_A}{\lambda_B} = \frac{1}{2} = \frac{d_B^2 n_B}{d_A^2 n_A}$$

$$\frac{n_A}{n_B} = \frac{2 \cdot d_B^2}{d_A^2}$$

$$\frac{n_A}{n_B} = \frac{2 \cdot d_B^2}{4d_B^2} = \frac{1}{2}$$

Chapter : Simple Harmonic Motion (S.H.M.)

Q.33 A cylindrical cork of uniform density floats in a liquid of density ρ_1 . If the cork is depressed slightly and released, period T. If the same cork floats in another liquid of density ρ_2 , then the similar oscillation has time period 2T. The value of ρ_2/ρ_1 is :

- (1) 1/4 (2) 4 (3) 2 (4) 1/2

Ans. [1]

Sol. Time period of a cylinder oscillating inside the liquid

$$T = 2\pi \sqrt{\frac{\rho_s l}{\rho_1 g}}$$

$$\frac{T_1}{T_2} = \sqrt{\frac{\rho_2}{\rho_1}} \quad [\because r_s \rightarrow \text{constant}]$$

$$\frac{T}{2T} = \sqrt{\frac{\rho_2}{\rho_1}}$$

$$\frac{\rho_2}{\rho_1} = \frac{1}{4}$$

Chapter : Sound wave

Q.34 For sound waves, if the number of nodes for the 5th harmonic of an open-ended pipe is n and that for the 9th harmonic of the same pipe with one of its ends closed is m, the ratio $\frac{n}{m}$ is

- (1) $\frac{3}{5}$ (2) $\frac{5}{9}$ (3) $\frac{9}{5}$ (4) 1

Ans. [4]

Sol. \rightarrow Number of nodes are same as number of harmonics

$$\therefore n = 5$$

For closed organ pipe

\rightarrow There are only odd harmonics

For 1st harmonic \rightarrow Number of node \rightarrow 1

For 3rd harmonic \rightarrow Number of node \rightarrow 2

For 5th harmonic \rightarrow Number of node \rightarrow 3

For 7th harmonic \rightarrow Number of node \rightarrow 4

For 9th harmonic \rightarrow Number of node \rightarrow 5

$$\therefore m = 5$$

$$\rightarrow \frac{n}{m} = \frac{5}{5} = 1$$

Chapter : Nuclear Physics

Q.35 Consider the following nuclear reaction :

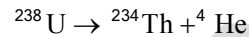

Take masses of ${}^{238}\text{U}$, ${}^{234}\text{Th}$ and ${}^4\text{He}$ as 238.050 u, 234.043 u and 4.003 u, respectively. The Q value for the reaction in keV, is :

[Given : 1 u = 931.5 MeV c^{-2}]

- (1) 3740 (2) 3726 (3) 3730 (4) 3736

Ans. [2]

Sol. Q-value for the nuclear reaction is given by,

$$Q = \Delta mc^2$$

${}^{238}\text{U} \rightarrow {}^{234}\text{Th} + {}^4\text{He}$ has mass defect

$$\Delta m = m_{\text{reactants}} - m_{\text{products}}$$

$$\Rightarrow \Delta m = 238.050 - (234.043 + 4.003) = 0.004 \text{ u}$$

$$\therefore Q = 0.004 \times 931.5 \text{ MeV} = 3.726 \text{ MeV} \\ = 3726 \text{ keV}$$

Chapter : Optical Instruments

Q.36 Which of the following measurements require 'index correction'?

- (1) Measurement of speed of sound using resonance tube
- (2) Measurement of resistance of a wire using meter bridge
- (3) Measurement of gravitational acceleration using simple pendulum
- (4) Measurement of focal length of lenses using optical bench

Ans. [4]

Sol. Index correction is an adjustment which need to perform in the experiments related to optical bench while measuring the focal length of lenses using optical bench.

Chapter : Gravitation

Q.37 In a solar system, the time period revolution of a planet tracing a circular orbit of radius R is proportional to :

- (1) R^3 (2) $R^{1/2}$ (3) $R^{3/2}$ (4) R^2

Ans. [3]

Sol. In planetary motion

$$T^2 \propto R^3$$

$$T \propto R^{3/2}$$

Chapter : Unit, Dimension & Error

Q.38 Consider that σ_s , k_B , b represent Stefan-Boltzmann constant, Boltzmann constant and Wien's displacement law constant, respectively.

The dimension of $\sigma_s k_B^{-1} b$ is

(1) $[L^{-1}T^{-1}K^{-4}]$ (2) $[L^{-1}T^{-1}K^{-2}]$

(3) $[L^{-1}K^{-2}]$ (4) $[L^{-1}T^{-1}K^{-3}]$

Ans. [2]

Sol. $\sigma_s = MT^{-3}K^{-4}$

$$k_B = M^1L^2T^{-2}K^{-1}$$

$$b = M^0LT^0K$$

$$\sigma_s k_B^{-1} b = [MT^{-3}K^{-4}][ML^{-1}L^{-2}T^2K][M^0LT^0K]$$

$$= T^{-1}K^{-2}L^{-1}$$

$$= L^{-1}T^{-1}K^{-2}$$

Chapter : Photoelectric Effect

Q.39 A ray of light with wavelength λ is incident on three different photo-electric cells namely 1, 2 and 3. The threshold wavelength of these photo-electric cells are λ_1 , λ_2 , and λ_3 , respectively and the magnitude of stopping potentials of these cells are V_1 , V_2 and V_3 , respectively. The relation between λ and threshold wavelengths are $\lambda_1 < \lambda$, $\lambda_2 > \lambda$ and $\lambda_3 \gg \lambda$. The correct option is :

(1) $V_1 < V_2, V_3 = 0$ (2) $V_1 = 0, V_2 < V_3$

(3) $V_1 = 0, V_2 > V_3$ (4) $V_1 > V_2, V_3 = 0$

Ans. [2]

Sol. For ejection of electron energy of incident photon should be greater than work function

$$\phi = \frac{hc}{\lambda}$$

$$\phi_1 = \frac{hc}{\lambda_1}$$

$$\lambda_1 < \lambda$$

$$\phi_1 > \phi$$

No electron will eject

$$V_1 = 0$$

By Einstein photoelectric equation

$$\phi = \phi_0 + eV$$

$$\lambda_2 > \lambda$$

$$\lambda_3 \gg \lambda$$

$$\phi > \phi_2$$

$$\phi \gg \phi_3$$

$$\text{So, } V_3 > V_2$$

Chapter : Practical Physics

Q.40 One main scale division of a Vernier calliper is equal to 1 mm and the number of divisions on the Vernier scale is 10. When both the jaws touch each other, the Vernier scale shifts to the left of zero of the main scale in such a way that 4th Vernier division coincides with a division of the main scale. If this Vernier calliper measures the length of a wire to be 1 cm, the actual length of the wire is:

(1) 1.04 cm (2) 0.60 cm

(3) 0.96 cm (4) 1.00 cm

Ans. [No option is correct]

Sol. \Rightarrow There is negative zero error

$$\Rightarrow \text{Zero error} = -(10 - 4) \times \text{L.C.} \dots (i)$$

From ... (i),

$$\text{Zero error} = -(10 - 4) \times 0.01 = -0.06 \text{ cm}$$

$$\Rightarrow \text{Zero correction} = - \text{Zero error}$$

$$= -(-0.06)$$

$$= 0.06 \text{ cm}$$

$$\Rightarrow \text{Correct reading} = R'$$

$$R' = R + \text{Zero correction}$$

$$= 1 + 0.06$$

$$= 1.06 \text{ cm}$$

\therefore No option is correct

Chapter : Gauss's Law

Q.41 A point charge Q is placed inside a cavity within a solid isolated conducting sphere. Consider points A, B and C as shown in the figure, where the magnitudes of the electric fields are E_A , E_B , and E_C respectively. The points B and C are at the same distance from the center of the solid sphere. The correct option is:

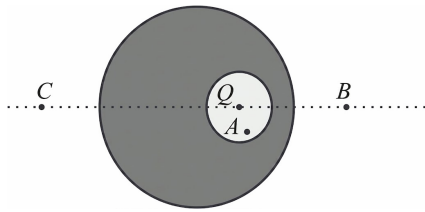

- (1) $E_A \neq 0, E_B < E_C$ (2) $E_A = 0, E_B = E_C$
 (3) $E_A \neq 0, E_B = E_C$ (4) $E_A = 0, E_B > E_C$

Ans. [3]

Sol. Due to charge Q present inside cavity, $E_A \neq 0$
 Charge distribution will be uniform on the outer surface of conducting sphere,
 Since B and C are at same distance from centre of sphere,
 $\therefore E_B = E_C$ (Due to electrostatic shielding)

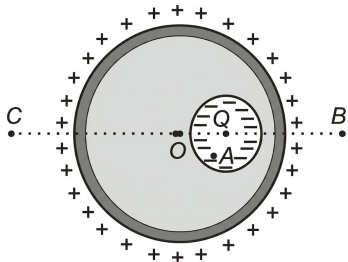

Chapter : Atomic Structure

Q.42 In Geiger-Marsden experiment, the number of scattered α -particles $N(\theta)$ is plotted as a function of scattering angle θ . Which of the following options represents the correct plot ?

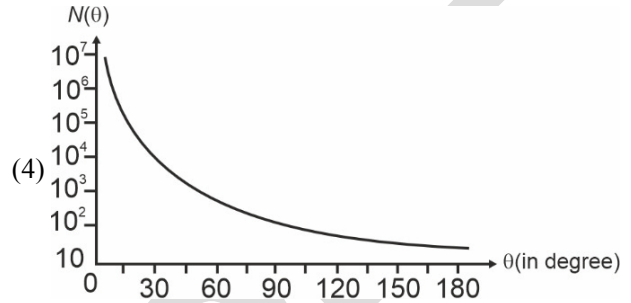
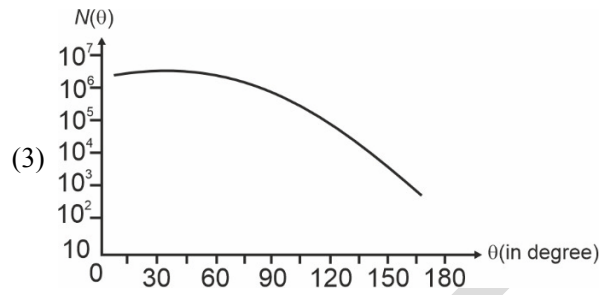
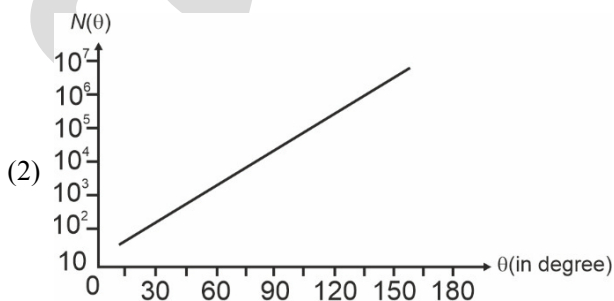
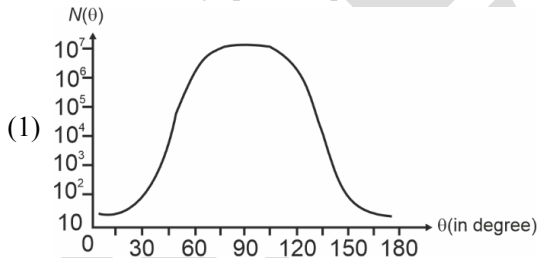

Ans. [4]

Sol. Number of scattered α -particles at angles (α)

$$= K \times \frac{1}{\sin^4\left(\frac{\alpha}{2}\right)}$$

$$= N(\theta) = \frac{K}{\sin^4\left(\frac{\theta}{2}\right)}$$

Graph will be $N(\theta)$

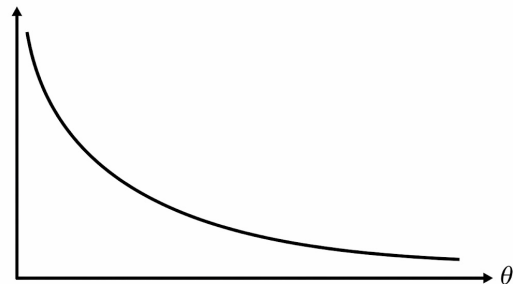

Chapter : Thermodynamics

Q.43 One mole of an ideal monatomic gas undergoes a cyclic process as shown in the figure. The total heat supplied to the gas is:

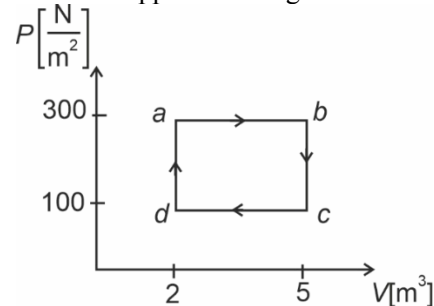

- (1) 800 J (2) 400 J (3) 500 J (4) 600 J

Ans. [4]

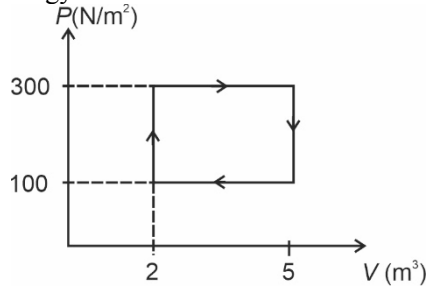
Sol. For any cyclic process, change in internal energy $\Delta U = 0$

Here, total heat exchange

$$\begin{aligned}\Delta Q &= W + \Delta U \\ &= W \\ &= (300 - 100)(5 - 2) \\ &= 200 \times 3 \\ &= 600 \text{ J}\end{aligned}$$

Chapter : Magnetic Effect of Current

Q.44 Two infinitely long parallel conducting wires A and B carry currents I and $2I$, respectively, in the same direction. The wire A has uniform mass per unit length λ and lies on an insulated floor. The wire B is kept fixed at a height h above the floor. The minimum magnitude of h so that the wire A does not rise from the floor is:

[g is the acceleration due to gravity and μ_0 is the permeability of free space.]

- (1) $\frac{4\mu_0 I^2}{\pi\lambda g}$ (2) $\frac{\mu_0 I^2}{2\pi\lambda g}$
 (3) $\frac{\mu_0 I^2}{\pi\lambda g}$ (4) $\frac{2\mu_0 I^2}{\pi\lambda g}$

Ans. [3]

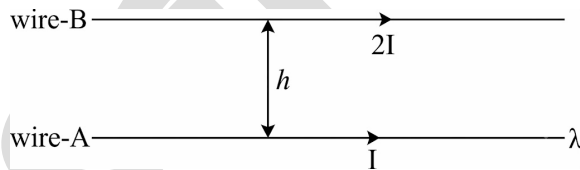
Sol.

Force per unit length on wire A by wire B

$$F = \frac{\mu_0}{4\pi} \frac{2I \cdot 2I}{h} = \frac{\mu_0}{4\pi} \frac{4I^2}{h}$$

If $F_{\text{net}} \leq$ weight of wire A, then wire does not rise from the floor.

$$\text{So, } F \leq mg$$

$$\frac{\mu_0}{4\pi} \frac{4I^2}{h} \leq \lambda g$$

$$\therefore h \geq \frac{\mu_0 I^2}{\pi\lambda g}$$

Chapter : Simple Harmonic Motion (S.H.M.)

Q.45 Consider a spring-mass simple harmonic oscillator in one dimension. The mass of the particle is m kg and the spring constant is $k \text{ Nm}^{-1}$. At a given instant, the extension of the spring is x meter and the speed of the particle is $v \text{ ms}^{-1}$. On the $x-v$ plane, if the graph of v as a function of x is a circle, then the correct option is:

- (1) $k = \sqrt{m}$ (2) $k = \frac{1}{m}$
 (3) $k = m$ (4) $k = m^2$

Ans. [3]

Sol. Velocity v as a function of x is given by

$$\begin{aligned}v &= \omega \sqrt{A^2 - x^2} \\ v^2 &= \omega^2 (A^2 - x^2) \\ \frac{v^2}{\omega^2} + x^2 &= A^2\end{aligned}$$

Given that above equation is of a circle

$$\text{Hence, } \omega^2 = 1$$

$$\begin{aligned}\frac{k}{m} &= 1 \\ k &= m\end{aligned}$$

CHEMISTRY
Chapter : Carbonyl Compounds

Q.46 Consider the following reaction, and choose the correct option.

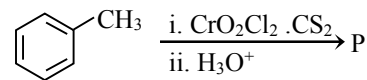

- (1) Compound P is obtained by the hydrogenation of benzoyl chloride with Pd on BaSO_4
 (2) On treating compound P with saturated NaHCO_3 solution, brisk effervescence is observed.
 (3) Compound P can be prepared by treating benzene with anhydrous AlCl_3 and CH_3COCl .
 (4) On treatment with bromine water, compound P gives a white precipitate.

Ans. [1]
Sol.

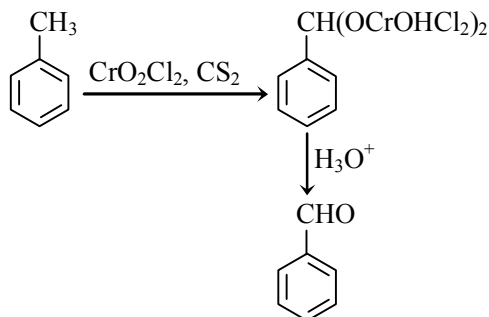

Compound P is obtained by

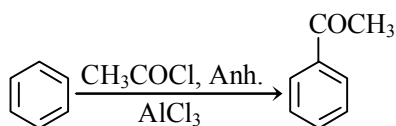
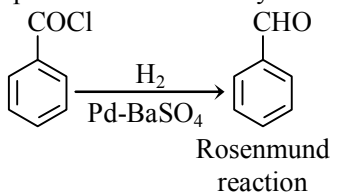

Chapter : Coordination Compound

Q.47 The formula of tetraammineaquachloridocobalt(III) chloride is:

- (1) $[\text{Co}(\text{NH}_3)_4(\text{H}_2\text{O})\text{Cl}]\text{Cl}_2$
- (2) $[\text{Co}(\text{NH}_3)_4\text{Cl}_2] \times \text{H}_2\text{O}$
- (3) $[\text{Co}(\text{NH}_3)_4]\text{Cl}_3 \times \text{H}_2\text{O}$
- (4) $[\text{Co}(\text{NH}_3)_4(\text{H}_2\text{O})\text{Cl}]\text{Cl}$

Ans. [1]

Sol. Tetraammineaquachloridocobalt(III) chloride is $[\text{Co}(\text{NH}_3)_4(\text{H}_2\text{O})\text{Cl}]\text{Cl}_2$.

Chapter : D & F Block

Q.48 The lanthanide ion having four unpaired electrons is

(Given : Atomic numbers of Ce = 58, Nd = 60, Tb = 65 and Ho = 67)

- (1) Ho^{3+}
- (2) Nd^{3+}
- (3) Ce^{3+}
- (4) Tb^{3+}

Ans. [1]

Sol. The outermost electronic configuration is

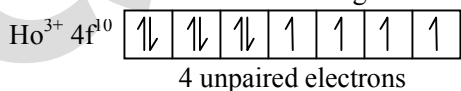

$\text{Nd}^{3+} 4f^3$ 3 unpaired electrons

$\text{Ce}^{3+} 4f^1$ 1 unpaired electron

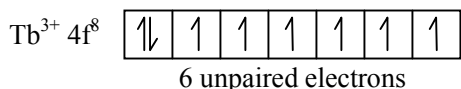

Chapter : Chemical Kinetics

Q.49 For an elementary chemical reaction, the Arrhenius plot is given below.

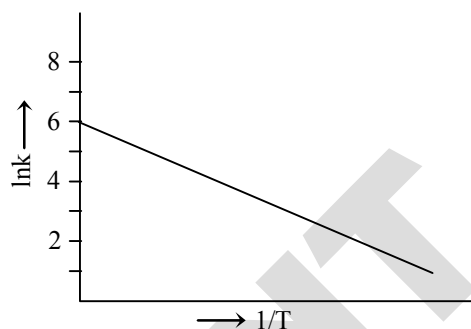

If the energy of activation is 6.64 kJ mol^{-1} and $R = 8.3 \text{ J K}^{-1} \text{ mol}^{-1}$, the temperature at which the rate constant becomes $e^2 \text{ min}^{-1}$, is

- (1) 250 K
- (2) 125 K
- (3) 150 K
- (4) 200 K

Ans. [4]

Sol. $\ln k = \ln A - \frac{E_a}{RT}$

$$\ln(e^2) = 6 - \frac{6.64 \times 10^3 \text{ J mol}^{-1}}{8.3 \text{ J K}^{-1} \text{ mol}^{-1} \times T}$$

$$2 = 6 - \frac{6.64 \times 10^3}{8.3 \times T}$$

$$T = \frac{6.64 \times 10^3}{8.3 \times 4} = 200 \text{ K}$$

Chapter : D & F Block

Q.50 The green paramagnetic species formed by heating KMnO_4 at 513 K is :

- (1) KO_2
- (2) K_2MnO_4
- (3) Mn_3O_4
- (4) MnO

Ans. [2]

Sol. $2\text{KMnO}_4 \rightarrow \text{K}_2\text{MnO}_4 + \text{MnO}_2 + \text{O}_2$
 K_2MnO_4 will form on heating KMnO_4 which has green colour.

Chapter : Hydrocarbon (Alkane, Alkene, Alkyne)

Q.51 Given below are two statements :

Statement I : *trans*-But-2-ene upon treatment with Br_2 in CCl_4 gives the following product.

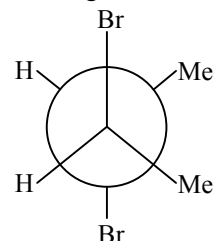

Statement II : *cis*-But-2-ene upon treatment with alkaline KMnO_4 gives the following product.

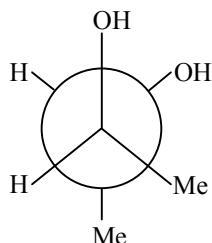

In the light of the above statements, choose the **most appropriate** answer from the options given below.

- (1) **Statement I** is incorrect but **Statement II** is correct
- (2) Both **Statement I** and **Statement II** are correct
- (3) Both **Statement I** and **Statement II** are incorrect
- (4) **Statement I** is correct but **Statement II** is incorrect

Ans. Sol. [1]

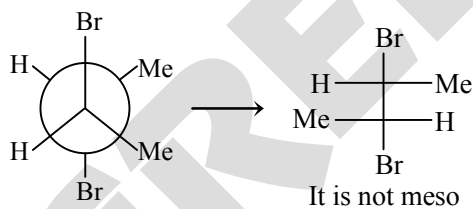
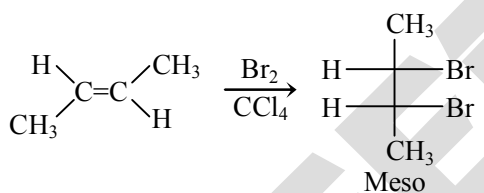

Therefore, statement-I is incorrect.

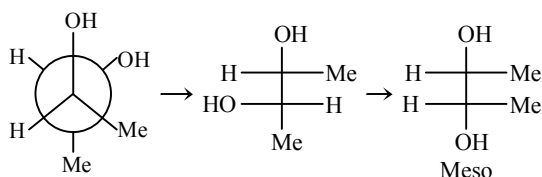
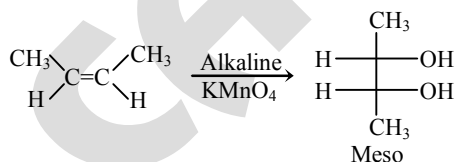

Chapter : Nitrogen Containing Compounds

Q.52 One of the products formed in the following reaction is :

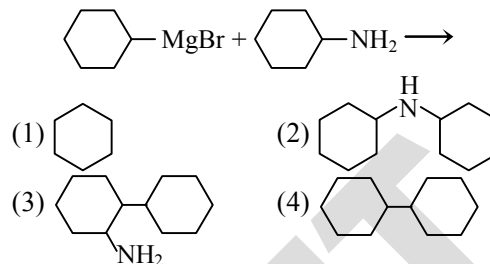

Ans. Sol. [1]

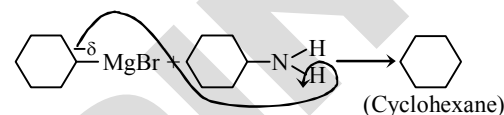

Grignard reagents react with amines to extract proton and convert into corresponding hydrocarbon.

Chapter : Practical Chemistry

Q.53 Given below are two statements :

Statement-I : Heating NaCl with concentrated H_2SO_4 and MnO_2 results in oxidation of Mn .

Statement-II : Heating NaI with concentrated H_2SO_4 and MnO_2 results in reduction of Mn .

In light of the above statements, choose the **most appropriate** answer from the options given below.

- (1) **Statement-I** is incorrect but **Statement-II** is correct
- (2) Both **Statement-I** and **Statement-II** are correct
- (3) Both **Statement-I** and **Statement-II** are incorrect
- (4) **Statement-I** is correct but **Statement-II** is incorrect

Ans. Sol. [1] Statement-I : (False)

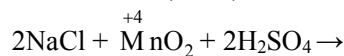

So, reduction of Mn is taking place.

Statement-II : (True)

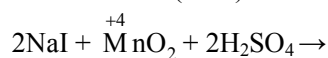

So, Mn has undergone reduction.

Chapter : Periodic Table

Q.54 Among the following options, the correct trend in the electron gain enthalpy is :

- (1) $I > Br > Cl > F$ (2) $F > Cl > Br > I$
 (3) $Br > Cl > F > I$ (4) $Cl > F > Br > I$

Ans. [4]
Sol.

Group 17 Elements	Electron gain enthalpy (kJ/mol)
F	-328
Cl	-349
Br	-325
I	-295

So, the correct order of electron gain enthalpy is $Cl > F > Br > I$.

Chapter : Coordination Compound

Q.55 Given below are two statements:

Statement-I : $[Fe(ox)_3]^{3-}$ is chiral.

Statement-II : $trans - [Cr(H_2O)_2(ox)_2]^-$ is chiral.

(Given : $oxH_2 = HOOC - COOH$)

In light of the above statements, choose the **most appropriate** answer from the options given below:

- (1) **Statement-I** is incorrect but **Statement-II** is correct
 (2) Both **Statement-I** and **Statement-II** are correct.
 (3) Both **Statement-I** and **Statement-II** are incorrect
 (4) **Statement-I** is correct but **Statement-II** is incorrect.

Ans. [4]
Sol.

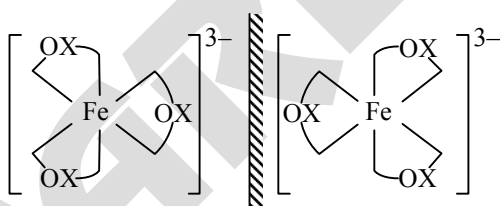

$[Fe(ox)_3]^{3-}$ is optically active and chiral with two non-superimposable mirror images.

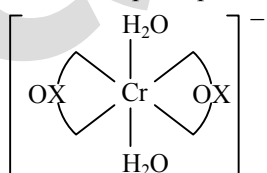

Plane of symmetry (POS) is present in given species.

\therefore It is NOT chiral and optically inactive.

Chapter : Biomolecules

Q.56 The correct statement about peptides and proteins is :

- (1) In α -helices, the polypeptide chain is twisted into a left-handed screw (helix) through intramolecular hydrogen bonds
 (2) Tertiary structure of proteins has two or more polypeptide subunits
 (3) Only the proteins having a quaternary structure are biologically active
 (4) In β -pleated sheet structures, peptide chains are held together by intermolecular hydrogen bonds

Ans. [4]

Sol. In β -pleated sheet structure, peptide chains are held together by intermolecular hydrogen bonds.

This is only correct statement.

Remaining (1), (2) and (3) are incorrect statements.

Chapter : Aromatic Hydrocarbon

Q.57 Given below are two statements:

Statement-I : Oxidation of p-nitrotoluene with acidic $KMnO_4$ gives an acid that is stronger than benzoic acid.

Statement-II : Reduction of p-nitrotoluene with Sn/HCl followed by neutralization gives an amine that is more basic than aniline.

In light of the above statements, choose the **most appropriate** answer from the options given below.

- (1) **Statement-I** is incorrect but **Statement-II** is correct
 (2) Both **Statement-I** and **Statement-II** are correct
 (3) Both **Statement-I** and **Statement-II** are incorrect
 (4) **Statement-I** is correct but **Statement-II** is incorrect

Ans. [2]

Sol. • Oxidation of p-nitrotoluene with acidic KMnO_4

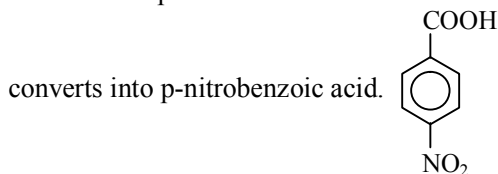

because of $-I$ effect and $-M$ effect, making p-nitrobenzoic acid as stronger acid than benzoic acid.

- Reduction of p-nitrotoluene with Sn/HCl followed by neutralization reduces the $(-\text{NO}_2)$ to an amino group $(-\text{NH}_2)$, forming p-toluidine.

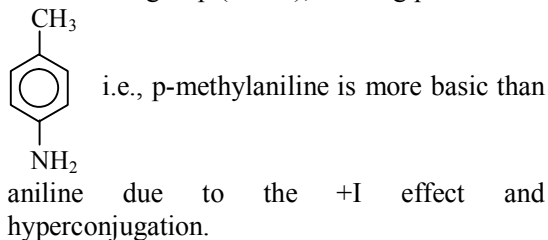

Chapter : Nitrogen Containing Compounds

Q.58 Identify the reactions which give aniline as the major product.

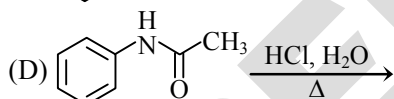
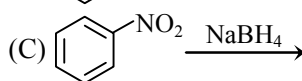
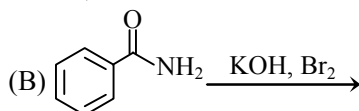
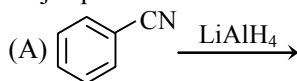

Choose the correct answer from the options given below.

- (1) C and D only (2) A and B only
 (3) B and D only (4) A and C only

Ans. [3]
Sol.

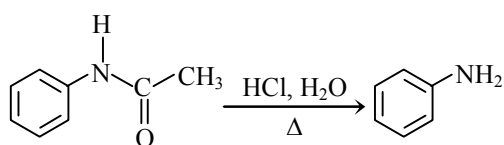
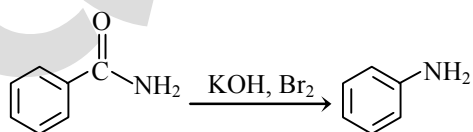
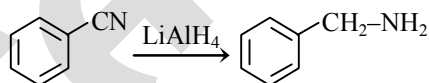

Chapter : Thermodynamics

Q.59 Two moles of an ideal gas undergo free expansion from 10 L to 100 L at 300 K. The values of ΔS_{system} and $\Delta S_{\text{surroundings}}$ are (R is universal gas constant)

- (1) $\Delta S_{\text{system}} = 4.606 R$; $\Delta S_{\text{surroundings}} = 0$
 (2) $\Delta S_{\text{system}} = 0$; $\Delta S_{\text{surroundings}} = 0$
 (3) $\Delta S_{\text{system}} = 4.606 R$; $\Delta S_{\text{surroundings}} = -4.606 R$
 (4) $\Delta S_{\text{system}} = 0$; $\Delta S_{\text{surroundings}} = 4.606 R$

Ans. [1]

Sol. During free expansion

$$\begin{aligned} \Delta S_{\text{system}} &= nR \ln \frac{V_2}{V_1} \\ &= 2.303 \times 2 \times R \times \log \frac{100}{10} \\ &= 4.606 R \end{aligned}$$

$$\Delta S_{\text{surroundings}} = 0 \text{ as } q = 0$$

Chapter : Carbonyl Compounds

Q.60 The compound that CANNOT be obtained from the aldol condensation reaction shown below, is :

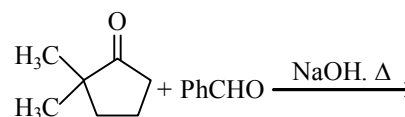

- (1)
- (2)
- (3)
- (4)

Ans. [2]

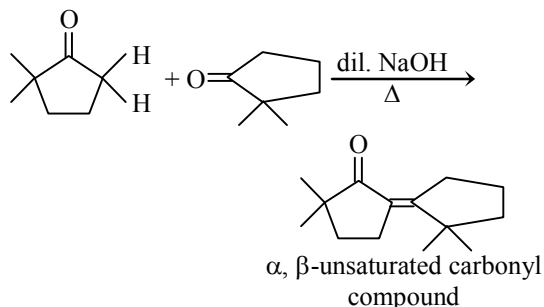
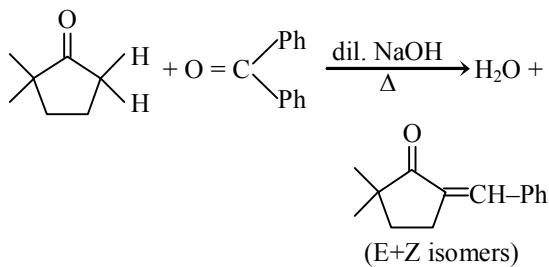
Sol.

Therefore, compound 2 cannot be obtained by aldol condensation of given compounds.

Chapter : Coordination Compound

Q.61 The complex which has facial and meridional isomers is :

(Given : py = pyridine and en = $\text{H}_2\text{N} - \text{CH}_2 - \text{CH}_2 - \text{NH}_2$)

- (1) $[\text{Ni}(\text{en})_2(\text{H}_2\text{O})_2]^{2+}$
- (2) $[\text{Cr}(\text{py})_3(\text{Cl})_3]$
- (3) $[\text{Cr}(\text{H}_2\text{O})_6]^{3+}$
- (4) $[\text{Co}(\text{NH}_3)_4(\text{H}_2\text{O})_2]^{3+}$

Ans. [2]

Sol. The complex with type $[\text{Ma}_3\text{b}_3]$ type of complexes show fac and mer type of isomers.
 $\therefore [\text{Cr}(\text{py})_3(\text{Cl})_3]$ shows fac and mer isomers.

Chapter : Mole Concept

Q.62 The numbers 17.0145 and 21.0235 were rounded to three figures after the decimal point. The resulting numbers, respectively, are

- (1) 17.015 and 21.024
- (2) 17.014 and 21.023
- (3) 17.015 and 21.023
- (4) 17.014 and 21.024

Ans. [4]

Sol. If the rightmost digit to be removed is 5, then the preceding number is not changed if it is an even number, but it is increased by one if it is an odd number.

Chapter : Mole Concept

Q.63 The amount of carbon dioxide evolved upon complete combustion of 116 g of n-butane is :
 (Given: atomic mass in amu H = 1, C = 12 and O = 16)

- (1) 362 g
- (2) 352 g
- (3) 322 g
- (4) 176 g

Ans. [2]

Sol. $\text{C}_4\text{H}_{10} + \frac{13}{2}\text{O}_2 \rightarrow 4\text{CO}_2 + 5\text{H}_2\text{O}$

\therefore 1 mole C_4H_{10} produces 4 mole CO_2

\therefore 58 g $\text{C}_4\text{H}_{10} \equiv 4 \times 44$ g CO_2

\therefore 116 g $\text{C}_4\text{H}_{10} \equiv \frac{4 \times 44}{58} \times 116 = 352$ g

Chapter : Atomic Structure

Q.64 Consider the following schematic plots of orbital wave function (ψ_r) against distance (r) from the nucleus.

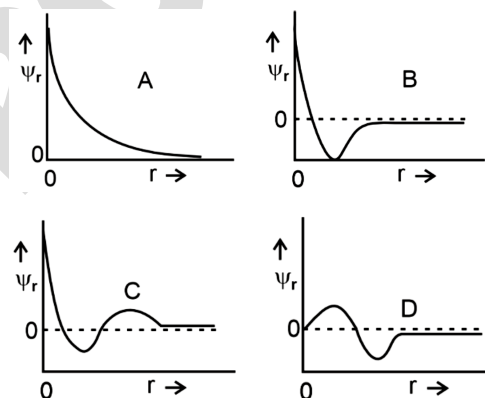

The figure representing two radial nodes in the orbital is :

- (1) D
- (2) A
- (3) B
- (4) C

Ans. [4]
Sol.

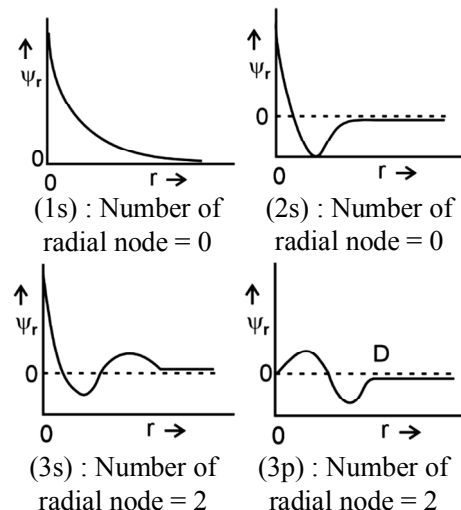

Chapter : General Organic Chemistry

Q.65 The following carbocation is stabilized by the interaction of the empty p orbital with

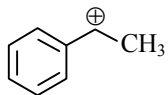

- (1) empty σ^* and empty π^* orbitals
- (2) filled σ and filled π orbitals
- (3) empty σ and empty π^* orbitals
- (4) empty σ^* and filled π orbitals

Ans. [2]

Sol.

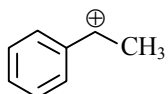

Due to resonance it is stabilised by filled π orbital.

Due to hyperconjugation, it is stabilised by filled σ orbitals.

Chapter : Coordination Compound

Q.66 A 1 : 3 electrolyte in an aqueous solution is

- (1) $[\text{Co}(\text{NH}_3)_3(\text{NO}_2)_3]$
- (2) $[\text{CoCl}_2(\text{NH}_3)_4]\text{Cl}$
- (3) $[\text{CoCl}(\text{NH}_3)_5]\text{Cl}_2$
- (4) $[\text{Co}(\text{NH}_3)_6]\text{Cl}_3$

Ans. [4]

Sol. The aqueous solution of $[\text{Co}(\text{NH}_3)_6]\text{Cl}_3$ is a type of 1 : 3 type electrolyte as it undergoes dissociation into $[\text{Co}(\text{NH}_3)_6]^{3+}$ and 3Cl^- ions.

Chapter : Electrochemistry

Q.67 The standard electrode potential (E°) for the half-cell reaction $\text{Fe}^{3+} + e^- \rightarrow \text{Fe}^{2+}$ at 298 K is

- (Given : $E^\circ(\text{Fe}^{3+}/\text{Fe}) = -0.04 \text{ V}$ and $E^\circ(\text{Fe}^{2+}/\text{Fe}) = -0.44 \text{ V}$ at 298 K)
- (1) +0.92 V
 - (2) +0.40 V
 - (3) +0.76 V
 - (4) -0.48 V

Ans. [3]

Sol.

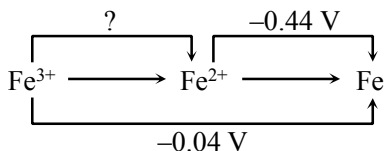

$$\Delta G^\circ_{\text{Fe}^{3+}/\text{Fe}} = \Delta G^\circ_{\text{Fe}^{3+}/\text{Fe}^{2+}} + \Delta G^\circ_{\text{Fe}^{2+}/\text{Fe}}$$

$$\begin{aligned} -nFE^\circ &= -nFE^\circ + -nFE^\circ \\ -3F(-0.04) &= -1FE^\circ + 2F(0.44) \\ 3F(0.04) &= -FE^\circ + 0.88F \\ 0.12 &= -E^\circ + 0.88 \\ 0.12 - 0.88 &= -E^\circ \\ -0.76 &= -E^\circ \\ E^\circ &= 0.76 \text{ V} \end{aligned}$$

Chapter : Practical Chemistry

Q.68 In potash alum, the ratio of K^+ and SO_4^{2-} ions is

- (1) 3 : 2
- (2) 1 : 2
- (3) 2 : 1
- (4) 2 : 3

Ans. [2]

Sol. Potash alum



No. of $\text{K}^+ = 2$

No. of $\text{SO}_4^{2-} = 4$

$$\text{Ratio } \frac{\text{K}^+}{\text{SO}_4^{2-}} = \frac{2}{4} = \frac{1}{2}$$

Chapter : Solution & Colligative Properties

Q.69 Consider the following statements about the solutions formed by mixing two liquids.

- A. An ideal solution thus formed obeys Raoult's law throughout the composition range.
- B. Mixture of chloroform and acetone shows negative deviation from Raoult's law.
- C. Mixture of aniline and phenol shows positive deviation from Raoult's law

- (1) A and C only
- (2) A and B only
- (3) B and C only
- (4) A only

Ans. [2]

Sol. In the case of phenol and aniline solution, the intermolecular hydrogen bonding between phenolic proton and lone pair on nitrogen atom of aniline is stronger than the respective intermolecular hydrogen bonding between similar molecules. Therefore it shows negative deviation.

Chapter : Electrochemistry

Q.70 For a salt **XY**, which is a strong electrolyte, the plot of Λ_m versus \sqrt{c} has a slope of $-90.0 \text{ S cm}^2 \text{ mol}^{-3/2} \text{ L}^{1/2}$ at 298 K. At 0.01 M concentration of **XY**, the value of Λ_m is $145.0 \text{ S cm}^2 \text{ mol}^{-1}$. The limiting molar conductivity of Y^- ion ($\lambda_{\text{Y}^-}^0$, in $\text{S cm}^2 \text{ mol}^{-1}$) at 298 K will be

(Given : $\lambda_{\text{X}^+}^0 = 74.0 \text{ S cm}^2 \text{ mol}^{-1}$)

- (1) 76.0 (2) 80.0
(3) 100.0 (4) 90.0

Ans. [2]

Sol. $y = mx + c$

slope = -90

According to $\lambda_m = \lambda_m^0 - A\sqrt{C}$

$$145 = \lambda_m^0 - 90 \times 0.1$$

$$\lambda_m^0 = 154 \text{ S cm}^2 \text{ mol}^{-1}$$

$$\lambda_{m(\text{XY})}^0 = \lambda_{\text{X}^+}^0 + \lambda_{\text{Y}^-}^0$$

$$154 = 74 + \lambda_{\text{Y}^-}^0$$

$$\lambda_{\text{Y}^-}^0 = 80 \text{ S cm}^2 \text{ mol}^{-1}$$

Chapter : General Organic Chemistry

Q.71 Arrange the following compounds in the increasing order of polarity

- A. $\text{CH}_3\text{CH}_2\text{OCH}_2\text{CH}_3$
B. $\text{CH}_3\text{CH}_2\text{OH}$
C. CH_3COCH_3
D. CH_3COOH

Choose the correct answer from the options given below.

- (1) $A < C < B < D$
(2) $A < B < C < D$
(3) $C < A < D < B$
(4) $C < A < B < D$

Ans. [1]

Sol. On the basis of polarity the correct order is
 $\text{C}_2\text{H}_5\text{OC}_2\text{H}_5 < \text{CH}_3\text{COCH}_3 < \text{CH}_3\text{CH}_2\text{OH} < \text{CH}_3\text{COOH}$
So correct order is
 $A < C < B < D$

Chapter : Coordination Compound

Q.72 According to crystal field theory, the correct order of ligands with respect to their decreasing order of field strength is

- (1) $\text{Cl}^- > \text{NH}_3 > \text{H}_2\text{O} > \text{CO}$
(2) $\text{CO} > \text{NH}_3 > \text{H}_2\text{O} > \text{Cl}^-$
(3) $\text{CO} > \text{H}_2\text{O} > \text{NH}_3 > \text{Cl}^-$
(4) $\text{Cl}^- > \text{H}_2\text{O} > \text{NH}_3 > \text{CO}$

Ans. [2]

Sol. The correct decreasing order of field strength according to crystal field theory is
 $\text{CO} > \text{NH}_3 > \text{H}_2\text{O} > \text{Cl}^-$

Chapter : Biomolecules

Q.73 The amino acid that gives a red-blood colour on treating its sodium fusion extract with sodium nitroprusside is

- (1) serine
(2) leucine
(3) threonine
(4) methionine

Ans. [4]

Sol. In case both nitrogen and sulphur are present in an organic compound, it gives blood red colour with sodium nitroprusside.

\therefore Methionine

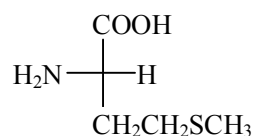
Chapter : Redox & Volumetric Analysis

Q.74 In an acidic medium, 10 mL of 0.25 M oxalic acid is titrated with KMnO_4 solution. If the volume of KMnO_4 solution required to reach end point is 10 mL, the strength of the KMnO_4 solution is

- (1) 0.15 M (2) 0.10 M
(3) 0.20 M (4) 0.25 M

Ans. [2]

Sol. $\text{KMnO}_4 + \text{H}_2\text{C}_2\text{O}_4 \xrightarrow{\text{H}^+} \text{Mn}^{2+} + 2\text{CO}_2 + \text{H}_2\text{O}$
No. of equivalent of $\text{KMnO}_4 = \text{No. of equivalent of } \text{H}_2\text{C}_2\text{O}_4$
 $10 \times 5 \times M = 10 \times 0.25 \times 2$

$$M = \frac{5}{10}$$

$$M = \frac{1}{10} = 0.10 \text{ M}$$

Chapter : Chemical Bonding

- Q.75** The correct statement is
- (1) Aluminium has five valence orbitals.
 - (2) Boron has a maximum covalency of four.
 - (3) Beryllium has three valence orbitals.
 - (4) Magnesium has a maximum covalency of four.

Ans. [2]

- Sol.**
- Aluminium has nine valence orbitals
 - Beryllium has four valence orbitals
 - Magnesium has a maximum covalency of six.
 - Boron has maximum covalency of four

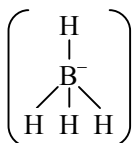

Chapter : IUPAC & Nomenclature

- Q.76** Among the following, the compound having conjugated double bonds is

- (1) hepta-1,6-diene
- (2) hepta-1,3-diene
- (3) hepta-1,4-diene
- (4) hepta-1,5-diene

Ans. [2]

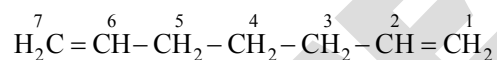
Sol. hepta-1,6-diene :



hepta-1,3-diene :



hepta-1,4-diene :



hepta-1,5-diene :



An organic compound (diene) with two double bonds separated by one single bond is termed as conjugated diene.

Chapter : Chemical Kinetics

- Q.77** $2\text{A} \xrightarrow{k} \text{B}$ is a zero-order reaction, where $k = 1.0 \text{ mol L}^{-1} \text{ min}^{-1}$. If the initial concentration of A is 2 M, then the time taken to complete 75% of the reaction will be

- (1) 2.0 min
- (2) 1.5 min
- (3) 0.75 min
- (4) 1.0 min

Ans. [3]

Sol. For zero order reaction

$$-\frac{1}{2} \frac{dA}{dt} = k$$

$$t = \frac{A_0 - A_t}{2k}$$

$$t = \frac{2 - 0.5}{2} = 0.75 \text{ min}$$

Chapter : Ionic Equilibrium

- Q.78** The correct order of solubility of the given salts in water at 298 K is

Salt	K_{sp} at 298 K
AgBr	5.0×10^{-13}
Zn(OH) ₂	1.0×10^{-15}
Hg ₂ Cl ₂	1.3×10^{-18}

- (1) Zn(OH)₂ > AgBr > Hg₂Cl₂
- (2) Hg₂Cl₂ > Zn(OH)₂ > AgBr
- (3) AgBr > Zn(OH)₂ > Hg₂Cl₂
- (4) Hg₂Cl₂ > AgBr > Zn(OH)₂

Ans. [1]

Sol. $\text{AgBr(s)} \rightleftharpoons \text{Ag}^+(\text{aq.}) + \text{Br}^-(\text{aq.})$

$$K_{sp} = 5 \times 10^{-13} = S^2$$

$$S = \sqrt{5 \times 10^{-13}}, S = 7.07 \times 10^{-7} \text{ mol/l}$$

$\text{Zn(OH)}_2(\text{s}) \rightleftharpoons \text{Zn}^{2+}(\text{aq.}) + 2\text{OH}^-(\text{aq.})$

$$K_{sp} = 10^{-15} = (S)(2S)^2$$

$$4S^3 = 10^{-15}, S = 0.63 \times 10^{-5} = 6.3 \times 10^{-6} \text{ mol/l}$$

$\text{Hg}_2\text{Cl}_2(\text{s}) \rightleftharpoons \text{Hg}_2^{2+}(\text{aq.}) + 2\text{Cl}^-(\text{aq.})$

$$K_{sp} = 1.3 \times 10^{-18} = 4S^3, S = 0.69 \times 10^{-6} = 6.9 \times 10^{-7} \text{ mol/l}$$

The correct order of solubility is:

Zn(OH)₂ > AgBr > Hg₂Cl₂

Chapter : Redox & Volumetric Analysis

- Q.79** The correct decreasing order of oxidation state of the underlined atom in each molecule is

- (1) P₄O₆ > Cl₂O₇ > AlH₃
- (2) P₄O₁₀ > SO₃ > H₂O
- (3) N₂O₅ > Al₂O₃ > H₂S
- (4) PbO₂ > N₂O₃ > SO₃

Ans. [3]

Sol. P₄⁺³O₆, Cl₂⁺⁷O₇, Al⁺³H₃

P₄⁺⁵O₁₀, S⁺⁶O₃, H₂O⁺²

N₂⁺⁵O₅, Al⁺³O₃, H₂S⁺²

Pb₂⁺⁴, N₂⁺³O₃, S⁺⁶O₃

Chapter : Thermodynamics

Q.80 Consider the reversible processes for 1.0 mol of an ideal gas as shown in the figure.

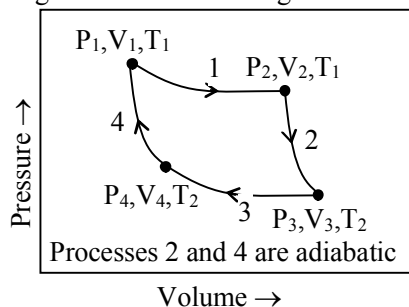

w_1, w_2, w_3 and w_4 represent work done (in calories) in the processes 1, 2, 3 and 4, respectively; ΔU_2 and ΔU_4 are changes in the internal energy for the processes 2 and 4, respectively.

[use $R = 2 \text{ cal K}^{-1} \text{ mol}^{-1}$]

The correct option is

(1) $w_1 + w_2 + w_3 + w_4 = 0$

(2) $w_1 + w_3 = -2T_1 \ln \frac{V_2}{V_1} - 2T_2 \ln \frac{V_4}{V_3}$

(3) $w_2 + w_4 = \Delta U_2 - \Delta U_4$

(4) $w_1 + w_2 = 2T_1 \ln \frac{V_2}{V_1}$

Ans. [2]

Sol. $w_1 \rightarrow$ isothermal reversible process

$$w_1 = -nRT_1 \ln \frac{V_2}{V_1}$$

$$w_1 = -1 \times R \times T_1 \ln \frac{V_2}{V_1}$$

$$w_3 = -n \times R \times T_2 \ln \frac{V_4}{V_3}$$

$$w_3 = -1 \times R \times T_2 \ln \frac{V_4}{V_3}$$

$$w_1 + w_3 = -nRT_1 \ln \left(\frac{V_2}{V_1} \right) - nRT_2 \ln \left(\frac{V_4}{V_3} \right)$$

$$w_1 + w_3 = -2T_1 \ln \left(\frac{V_2}{V_1} \right) - 2T_2 \ln \left(\frac{V_4}{V_3} \right)$$

Chapter : Solution & Colligative Properties

Q.81 Assertion A: For an ideal solution formed by mixing liquids **P** and **Q**, $\Delta_{\text{mix}} H = 0$ and $\Delta_{\text{mix}} V = 0$

Reason R: No interactions occur between **P** and **Q**

In the light of the above statements, choose the **most appropriate** answer from the options given below.

- (1) **A** is not correct but **R** is correct
- (2) Both **A** and **R** are correct and **R** is the correct explanation of **A**
- (3) Both **A** and **R** are correct but **R** is **NOT** the correct explanation of **A**
- (4) **A** is correct but **R** is not correct

Ans. [4]

Sol. For ideal solution, $\Delta_{\text{mix}} H = 0$ and $\Delta_{\text{mix}} V = 0$
In Ideal solution energy required to break interaction between P-P and Q-Q will be same as the energy released on the interaction of P-Q.

Chapter : Coordination Compound

Q.82 Among the species given below, the spin-only magnetic moment is highest for (Given: Atomic number of Ti = 22, Mn = 25, Fe = 26 and Co = 27)

- (1) $[\text{Ti}(\text{H}_2\text{O})_6]^{3+}$
- (2) $[\text{Mn}(\text{CN})_6]^{3-}$
- (3) $[\text{Fe}(\text{CN})_6]^{3-}$
- (4) $[\text{Co}(\text{NH}_3)_6]^{3+}$

Ans. [2]

Sol. In $[\text{Ti}(\text{H}_2\text{O})_6]^{3+} \Rightarrow \text{Ti}^{3+} \Rightarrow [\text{Ar}] 4s^0 3d^1$
Number of unpaired electron = 1
In $[\text{Mn}(\text{CN})_6]^{3-} \Rightarrow \text{Mn}^{3+} \Rightarrow [\text{Ar}] 4s^0 3d^4$
Number of unpaired electrons = 2

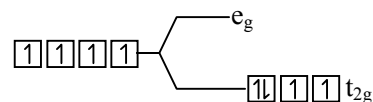

In $[\text{Fe}(\text{CN})_6]^{3-} \Rightarrow \text{Fe}^{3+} \Rightarrow [\text{Ar}] 4s^0 3d^5$

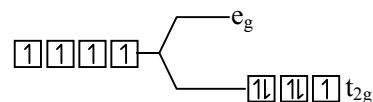

Number of unpaired electron = 1

Chapter : Thermodynamics

Q.83 A protein undergoes reversible thermal denaturation from its initial state **N** to denatured state **D** according to $\text{N} \rightleftharpoons \text{D}$. At 60°C, the concentrations of both **N** and **D** are equal at equilibrium, and the standard enthalpy change of denaturation is 666 kJ mol⁻¹. The standard entropy change ΔS° in kJ K⁻¹ mol⁻¹ of the protein upon denaturation at 60°C is closest to

- (1) 11.1
- (2) 2.0
- (3) 2000.0
- (4) 333.0

Chapter : Chemical Bonding

Q.88 Match the species in **List-I** with their geometry in **List-II**.

	List-I		List-II
A.	PCl ₅	I.	Tetrahedral
B.	BrF ₅	II.	Square Planar
C.	BF ₄ ⁻	III.	Trigonal bipyramidal
D.	[Ni(CN) ₄] ²⁻	IV.	Square pyramidal

Choose the **correct** answer from the options given below:

- (1) A-III, B-II, C-I, D-IV
- (2) A-IV, B-III, C-I, D-II
- (3) A-III, B-IV, C-I, D-II
- (4) A-III, B-I, C-II, D-IV

Ans. Sol.

[3]

	Compound	Hybridization of central atom/ion	Geometry
A.	PCl ₅	sp ³ d	Trigonal bipyramidal
B.	BrF ₅	sp ³ d ²	Square pyramidal
C.	BF ₄ ⁻	sp ³	Tetrahedral
D.	[Ni(CN) ₄] ²⁻	dsp ²	Square planar

Chapter : Biomolecules

Q.89 Match the vitamins in **List I** with their sources in **List II**

	Vitamin		List-II
A.	vitamin A	I.	Meat
B.	vitamin B ₁₂	II.	sunflower oil
C.	vitamin E	III.	green leafy vegetables
D.	vitamin K	IV.	Carrots

Choose the **correct** answer from the options given below:

- (1) A-III, B-I, C-IV, D-II
- (2) A-II, B-III, C-IV, D-I
- (3) A-IV, B-I, C-II, D-III
- (4) A-IV, B-II, C-I, D-III

Ans. Sol.

[3]

	Vitamin	Sources
A.	vitamin A	Carrot
B.	vitamin B ₁₂	Meat
C.	vitamin E	Sunflower oil
D.	vitamin K	Green leafy vegetables

Chapter : Carbonyl Compounds

Q.90 For the following reaction sequence, choose the correct option

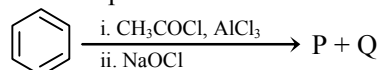

- (1) Both **P** and **Q** are carbonyl compounds
- (2) If **P** is the sodium salt of a carboxylic acid, **Q** is a primary alcohol
- (3) **P** and **Q** are aromatic compounds
- (4) If **P** gives a carboxylic acid on acidification, **Q** gives a poisonous gas on exposure to air and light

Ans. Sol. [4]

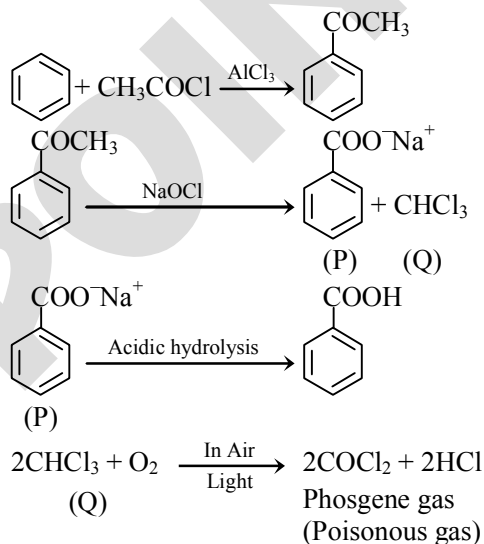
BIOLOGY
Chapter : Animal kingdom

Q.91 Given below are two statements:

Statement I: The class name Reptilia refers to creeping or crawling mode of locomotion.

Statement II: All organisms belonging to Reptilia have three chambered heart.

In the light of the above statements, choose the most appropriate answer from the options given below:

- (1) Statement I is incorrect but Statement II is correct
- (2) Both Statement I and Statement II are correct
- (3) Both Statement I and Statement II are incorrect
- (4) Statement I is correct but Statement II is incorrect

Ans. [4]

Sol. The class Reptilia refers to their creeping or crawling mode of locomotion. Heart is usually three-chambered, but four-chambered in crocodiles.

So, All organisms belonging to class Reptilia does not possess three chambered heart.

Chapter : Photosynthesis

Q.92 How many turns of Calvin cycle are required for the formation of three molecules of glucose?

- (1) 18 (2) 6 (3) 3 (4) 1

Ans. [1]

Sol. To make one molecule of glucose 6 turns of the cycle are required.

Therefore, for the formation of three molecules of glucose, $6 \times 3 = 18$, turns of Calvin cycle are required.

Chapter : Photosynthesis

Q.93 Photorespiration reaction catalyzed by RuBisCo is shown below:

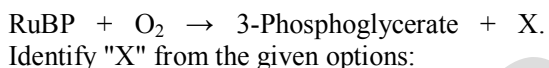

- (1) Malate
 (2) Phosphoenolpyruvate
 (3) 2-Phosphoglycolate
 (4) Oxaloacetate

Ans. [3]

Sol. During the process of photorespiration, RuBP binds with O₂ and RuBP instead of being converted to 2 molecules of PGA, forms one molecule each of phosphoglycerate and phosphoglycolate.

Hence, in the given reaction, the "X" is 2-phosphoglycolate.

Chapter : Plant Kingdom

Q.94 Given below are two statements:

Statement I: In gymnosperms, the male and female gametophytes remain within the sporangia.

Statement II: In gymnosperms, seeds are not covered.

In the light of the above statements, choose the most appropriate answer from the options given below:

- (1) Statement I is incorrect but Statement II is correct
- (2) Both Statement I and Statement II are correct
- (3) Both Statement I and Statement II are incorrect
- (4) Statement I is correct but Statement II is incorrect

Ans. [2]

Sol. In gymnosperm, the male and female gametophytes do not have an independent free-living existence. They remain within sporangia, retained on the sporophyte.

In gymnosperms the ovules are not enclosed by any ovary wall and remain exposed, both before and after fertilisation. The seeds that develop post fertilisation, are not covered, i.e., naked.

Chapter : Respiration in Plants

Q.95 How many molecules of pyruvic acid are produced at the end of glycolysis from 206 molecules of glucose?

- (1) 412 (2) 206
 (3) 309 (4) 103

Ans. [1]

Sol. Two molecules of pyruvic acid are formed at the end of glycolysis from one molecule of glucose.

From 206 molecules of glucose, 412 molecules of pyruvic acid are formed.

Chapter : Plant Kingdom

Q.96 Match List-I with List-II.

	List-I		List-II
A.	Fusion of protoplasm between gametes	I.	Meiosis
B.	Fusion of two nuclei	II.	Plasmogamy
C.	Generation of haploid spores	III.	Karyogamy

Choose the correct answer from the options given below :

- (1) A-I, B-III, C-II (2) A-II, B-III, C-I
 (3) A-II, B-I, C-III (3) A-III, B-II, C-I

Ans. [2]

Sol. Karyogamy involve fusion of two nuclei.
Plasmogamy is fusion of protoplasm.
Meiosis leads to the production of haploid spores.

Chapter : Cell : The Unit of Life

Q.97 Mitochondrial inner membrane encloses
(1) aqueous humor (2) matrix
(3) cytosol (4) mucus

Ans. [2]

Sol. Mitochondrial inner membrane encloses matrix.

Chapter : Morphology of Flowering Plants

Q.98 Phyllotaxy is the pattern of arrangement of
(1) sepals (2) leaves
(3) flowers (4) fruits

Ans. [2]

Sol. Phyllotaxy is the pattern of arrangement of leaves on the stem.

Chapter : Biological Classification

Q.99 Mad cow disease is caused by
(1) *Mycoplasma sp.*
(2) prions
(3) viroids
(4) *Aspergillus sp.*

Ans. [2]

Sol. Mad cow disease is caused by prions.

Chapter : Cell : The Unit of Life

Q.100 Cell theory was formulated by
(1) Antonie Von Leeuwenhoek
(2) Schleiden and Schwann
(3) Robert Brown
(4) Singer and Nicolson

Ans. [2]

Sol. Cell theory was formulated by Schleiden and Schwann.

Chapter : Plant Growth and Development

Q.101 Which of the following plant growth regulators promotes internode elongation prior to flowering in cabbage?
(1) Ethephon (2) Abscisic acid
(3) Gibberellin (4) Indole butyric acid

Ans. [3]

Sol. Gibberellin promotes internode elongation prior to flowering in cabbage.

Chapter : Photosynthesis

Q.102 Which pigment has absorption peak at 700 nm in the photosynthetic reaction centre PS I (P700)?
(1) Carotenoids
(2) Chlorophyll b
(3) Chlorophyll a
(4) Xanthophylls

Ans. [3]

Sol. In PSI, the reaction centre chlorophyll a has an absorption peak at 700 nm and hence, is called P₇₀₀.

Chapter : Plant Kingdom

Q.103 Sphenopsida class belongs to
(1) pteridophytes (2) bryophytes
(3) angiosperms (4) gymnosperms

Ans. [1]

Sol. Sphenopsida class belongs to pteridophytes.

Chapter : Locomotion and Movement

Q.104 Which of the following represents the correct sequence of arrangement of bones in the lower limb of humans?
(1) Femur-tarsal-patella-tibia
(2) Femur-tibia-patella-tarsal
(3) Patella-femur-tibia-tarsal
(4) Femur-patella-tibia-tarsal

Ans. [4]

Sol. Each hindlimb consists of 30 bones.

- The bones of the lower limb is femur (thigh bone), A cup shaped bone called patella cover the knee ventrally (knee cap), tibia and fibula, tarsals (ankle bones), metatarsals and phalanges.
- So, the correct sequence of arrangement of bones in the lower limb of humans will be Femur - patella tibia -tarsal.

Chapter : Plant Growth and Development

Q.105 Which of the following plant growth regulators is used as herbicide?
(1) Gibberellin (2) 2, 4-D
(3) Kinetin (4) Abscisic acid

Ans. [2]

Sol. 2, 4-D is an artificial auxin, which is widely used as herbicide.

Chapter : The Living World

- Q.106** Genus represents _____.
- (1) a group of closely related families
 - (2) an individual plant or animal
 - (3) a population of plants and animals
 - (4) a group of closely related species

Ans. [4]

Sol. Genus comprises a group of related species which has more characters in common in comparison to species of other genera.

Chapter : Cell : The Unit of Life

- Q.107** The plastid that stores xanthophyll is known as
- (1) amyloplast
 - (2) chloroplast
 - (3) chromoplast
 - (4) aleuroplast

Ans. [3]

Sol. The plastid that stores xanthophyll is known as chromoplast.

Chapter : STRUCTURAL ORGANISATION IN ANIMALS (Lower Animals)

- Q.108** In water, frogs respire using
- (1) trachea
 - (2) skin
 - (3) buccal cavity
 - (4) lungs

Ans. [2]

Sol. Frogs respire on land and in water by different methods. In water, skin acts as aquatic respiratory organ (cutaneous respiration). Dissolved oxygen in the water is exchanged through the skin by diffusion. On land, the buccal cavity, skin and lungs act as the respiratory organs.

Chapter : Animal kingdom

- Q.109** Which of the following is not a characteristic of chordates?
- (1) Presence of post anal part (tail)
 - (2) Presence of notochord
 - (3) Central nervous system is dorsal
 - (4) Absence of gills

Ans. [4]

Sol. The members of phylum Chordata shows following features at any stage of life.

- (1) Presence of notochord
- (2) Pharynx perforated by gill slits
- (3) Dorsal, hollow and single central nervous system central
- (4) Ventral heart
- (5) A post-anal tail

Gill slits are absent in non-chordates.

Chapter : Cell : The Unit of Life

- Q.110** Smooth endoplasmic reticulum _____.
- (1) is a site for the synthesis of carbohydrates
 - (2) has ribosomes attached to its surface
 - (3) is the major site for the synthesis of lipids
 - (4) is actively involved in protein synthesis

Ans. [3]

Sol. The Smooth Endoplasmic Reticulum (SER) is responsible for synthesis of lipids as well as steroidal hormones. It is not associated with ribosomes and hence appears smooth.

Rough endoplasmic reticulum is actively involved in protein synthesis. Carbohydrate synthesis occurs in chloroplasts.

Chapter : Cell : The Unit of Life

- Q.111** Which of the following are characteristics of prokaryotic cells?

- (a) Ribosomes are made of 50S and 30S subunits
- (b) They can have plasmids
- (c) They contain mesosome
- (d) They have peroxisomes

Choose the correct answer from the options given below :

- (1) (a), (b) and (c) only
- (2) (b) and (c) only
- (3) (a) and (c) only
- (4) (a), (c) and (d) only

Ans. [1]

Sol. The following are characteristics of prokaryotic cells.

- Ribosomes are made of 50S and 30S subunits (70S Ribosomes)
- They can have plasmids (Extra chromosomal DNA)
- They contain mesosome (Infoldings of plasma membrane)
- They do not possess membrane bound organelles such as peroxisomes.

Chapter : Cell : The Unit of Life
Q.112 Match List-I with List-II.

	List-I		List-II
A.	Cristae	I.	Flat membrane sacs in stroma of chloroplast
B.	Cisternae	II.	Infoldings in mitochondria
C.	Thylakoids	III.	Cell membrane
D.	Phospholipid	IV.	Disc shaped sacs in the Golgi apparatus

Choose the correct answer from the options given below:

- (1) A-IV, B-III, C-I, D-II
- (2) A-III, B-IV, C-I, D-II
- (3) A-II, B-IV, C-I, D-III
- (4) A-II, B-IV, C-III, D-I

Ans. [3]

Sol. Following are the correct matches:

A.	Cristae	I.	Infoldings in mitochondria
B.	Cisternae	II.	Disc shaped sacs in the Golgi apparatus
C.	Thylakoids	III.	Flat membrane sacs in stroma of chloroplast
D.	Phospholipid	IV.	Cell membrane

Chapter : Chemical Coordination and Regulation
Q.113 Which of the following statements related to pituitary gland are correct?

- (a) It is divided anatomically into adenohypophysis and neurohypophysis
- (b) It secretes follicle stimulating hormone
- (c) It secretes melanocyte stimulating hormone
- (d) It does not secrete prolactin

Choose the correct answer from the options given below :

- (1) (b) and (c) only
- (2) (a) and (b) only
- (3) (a), (b) and (c) only
- (4) (c) and (d) only

Ans. [3]

Sol. Adenohypophysis of pituitary gland also secretes prolactin.

Chapter : Photosynthesis
Q.114 Which of the following statements regarding photorespiration are correct?

- (a) Do not occur in C_3 plants
- (b) CO_2 is consumed and O_2 is generated
- (c) Phosphoglycolate is formed
- (d) No synthesis of ATP and NADPH

Choose the correct answer from the options given below:

- (1) (a) and (b) only
- (2) (a) and (d) only
- (3) (c) and (d) only
- (4) (b) and (d) only

Ans. [3]

Sol.

- Photorespiration can occur in C_3 plants.
- In photorespiration, O_2 is consumed and CO_2 is released.
- Phosphoglycolate is formed as the initial product.
- There is no synthesis of ATP and NADPH in photorespiration.

Chapter : Body Fluids and Circulation
Q.115 Which of the following statements is incorrect?

- (1) Fibrinogen is produced from fibrin
- (2) Blood coagulates in response to an injury
- (3) Blood clot consists of fibrins
- (4) Fibrin is produced from fibrinogen

Ans. [1]

Sol. Fibrins are formed by the conversion of inactive fibrinogen in the plasma by the enzyme thrombin.

Chapter : The Living World
Q.116 Arrange the following taxonomic categories in ascending order.

- (a) Genus
- (b) Class
- (c) Order
- (d) Phylum
- (e) Family
- (f) Kingdom
- (g) Species

Choose the correct answer from the options given below:

- (1) (f), (c), (b), (g), (d), (e), (a)
- (2) (g), (a), (e), (c), (b), (d), (f)
- (3) (a), (c), (d), (g), (f), (b), (e)
- (4) (g), (c), (d), (b), (e), (a), (f)

Ans. [2]

Sol. The following is the arrangement of taxonomic categories in ascending order.

Species (g), Genus (a), Family (e), Order (c), Class (b), Phylum (d), Kingdom (f).

Chapter : Photosynthesis

Q.117 Select the correct sequence of experiments that led to a gradual understanding of photosynthesis in green plants.

- (1) Production of glucose → role of air → release of oxygen → absorption spectra of chlorophyll a and b
- (2) Absorption spectra of chlorophyll a and b → production of glucose → release of oxygen → role of air
- (3) Role of air → release of oxygen → production of glucose → absorption spectra of chlorophyll a and b
- (4) Release of oxygen → production of glucose → absorption spectra of chlorophyll a and b → role of air

Ans. [3]

Sol. Following is the appropriate sequence of experiments that led to a gradual understanding of photosynthesis in green plants.

Role of air in Glucose (Joseph Priestley's bell jar experiment) 1770

↓

Release of oxygen (Jan Ingenhousz's usz's Lotus experiment aquatic plant)

↓

Production of Glucose (Julius Von Sach's S experiment) 1854

↓

Absorption spectra of chlorophyll a and b (T.W. Engelmann's experiment)

Chapter : Biomolecules

Q.118 Match List-I with List-II.

	List-I		List-II
A.	Starch	I.	Fight infection
B.	Antibody	II.	Energy storage
C.	Concanavalin A	III.	Glucose transport
D.	Glut-4	IV.	Lectin

Choose the correct answer from the options given below :

- (1) A-I, B-II, C-III, D-IV
- (2) A-I, B-II, C-IV, D-III
- (3) A-II, B-I, C-IV, D-III
- (4) A-II, B-I, C-III, D-IV

Ans. [3]

Sol. Starch → Energy storage
Antibody → Fight infection
Concanavalin A → Lectin
Glut-4 → Glucose transport

Chapter : Locomotion and Movement

Q.119 The number of vertebrae in a human is _____.

- (1) 206
- (2) 7
- (3) 12
- (4) 26

Ans. [4]

Sol. The number of vertebrae in adult human is 26.

Chapter : Cell : The Unit of Life

Q.120 Endomembrane system includes _____.

- (1) Golgi complex, chloroplast, peroxisomes and vacuole
- (2) endoplasmic reticulum, Golgi complex, lysosomes and vacuole
- (3) endoplasmic reticulum, chloroplast, peroxisomes and vacuole
- (4) mitochondria, chloroplast, peroxisomes and vacuole

Ans. [2]

Sol. Endomembrane system includes organelles whose functions are coordinated includes total four organelles, namely Endoplasmic reticulum, Golgi body, vacuole and lysosomes.

Chapter : Plant Growth and Development

Q.121 Length of the stem at time 0 is 20 cm. The arithmetic growth rate is 30 cm per day. What is the length of the stem at the end of the 7th day?

- (1) 460 cm (2) 50 cm
(3) 170 cm (4) 230 cm

Ans. [4]

Sol. Arithmetic growth can be expressed as :

$L_t = L_0 + rt$ [where, L_t = length at time 't', L_0 = Length at time 'zero', r = growth rate]

$$L_{7\text{thday}} \Rightarrow 20 + 30 \times 7$$

$$\Rightarrow 20 + 210$$

$$\Rightarrow 230 \text{ cm}$$

The length of the stem at the end of 7th day is 230 cm.

Chapter : Biological Classification

Q.122 Match List-I with List-II.

	List-I		List-I
A.	Spherical	I.	Vibrio
B.	Rod	II.	Cocci
C.	Comma	III.	Spirilla
D.	Spirillum	IV.	Bacilli

Choose the correct answer from the options given below :

- (1) A-II, B-IV, C-I, D-III
(2) A-I, B-III, C-II, D-IV
(3) A-III, B-II, C-I, D-IV
(4) A-II, B-I, C-IV, D-III

Ans. [1]

Sol. Bacteria are grouped under four categories based on their shape :

Spherical → Coccus

Rod-shaped → Bacillus

Comma-shaped → Vibrium

Spiral → Spirillum

Chapter : Body Fluids and Circulation

Q.123 The number of action potentials generated by sino-atrial node (SAN) in a healthy human is _____ per minute.

- (1) 120 – 140 (2) 28 – 30
(3) 70 – 75 (4) 100 – 110

Ans. [3]

Sol. The number of action potentials generated by sino-atrial node (SAN) in a healthy human is 70 – 75 per minute.

Chapter : The Living World

Q.124 Match List-I with List-II.

	List-I		List-II
A.	Family	I.	Sapindales
B.	Genus	II.	Dicotyledonae
C.	Class	III.	Anacardiaceae
D.	Phylum	IV.	Angiospermae
E.	Order	V.	<i>Mangifera</i>

Choose the correct answer from the options given below :

- (1) A-III, B-V, C-II, D-IV, E-I
(2) A-I, B-V, C-II, D-IV, E-III
(3) A-II, B-I, C-III, D-IV, E-V
(4) A-II, B-III, C-V, D-I, E-IV

Ans. [1*]

Sol. *Mangifera* represents Genus, Anacardiaceae represents family, Sapindales represents order, Dicotyledonae represents class, Phylum Angiospermae [correct should be division]

Chapter : Neural Control and Coordination

Q.125 Which of the following is not a part of human central neural system?

- (1) Pericardium (2) Arachnoid
(3) Dura mater (4) Pia mater

Ans. [1]

Sol. Pericardium is a double walled membranous bag that protects the heart.

Arachnoid, dura mater and pia mater are meninges, which cover the brain inside the skull.

Chapter : Cell Cycle and Cell Division

Q.126 Given below are two statements :

Statement I : Chromosomes are fully condensed at the end of prophase I.

Statement II : Meiosis I resembles mitosis.

In the light of the above statements, choose the most appropriate answer from the options given below :

- (1) Statement I is incorrect, but Statement II is true
(2) Both Statement I and Statement II are true
(3) Both Statement I and Statement II are false
(4) Statement I is correct, but Statement II is false

Ans. [4]

Sol. The final stage of meiotic prophase-I is diakinesis. So, at the end of prophase-I the chromosomes are fully condensed and the meiotic spindle is assembled to prepare the homologous chromosomes for separation. So, Statement I is correct.

Meiosis II resembles mitosis as it is an equational division.

Chapter : Morphology of Flowering Plants

Q.127 Match List-I with List-II.

	List-I		List-II
A.	Marginal placentation	I.	<i>Argemone</i>
B.	Axile placentation	II.	Tomato
C.	Parietal placentation	III.	<i>Primrose</i>
D.	Free central placentation	IV.	Pea

Choose the correct answer from the options given below :

- (1) A-IV, B-II, C-I, D-III
- (2) A-II, B-IV, C-I, D-III
- (3) A-IV, B-II, C-III, D-I
- (4) A-IV, B-III, C-I, D-II

Ans. [1]

Sol. Marginal placentation – Pea
Axile placentation – Tomato
Parietal placentation – *Argemone*
Free central placentation – *Primrose*

Chapter : Biological Classification

Q.128 Symbiotic association between fungi and algae are called _____.

- (1) chrysophytes
- (2) lichens
- (3) sponges
- (4) mycorrhiza

Ans. [2]

Sol. Lichens are symbiotic associations i.e. mutually useful associations, between algae and fungi.
Mycorrhiza are associations between fungi and roots of higher plants.

Chapter : Biological Classification

Q.129 Which of the following is not a prokaryote?

- (1) Fungi
- (2) Bacteria
- (3) Blue green algae
- (4) Mycoplasma

Ans. [1]

Sol. The prokaryotic cells are represented by bacteria, blue-green algae, Mycoplasma and PPLO. Fungi are eukaryotic organisms.

Chapter : Biomolecules

Q.130 Arrange the following elements in descending order of their contribution to percentage weight of the human body.

- (a) Oxygen
- (b) Carbon
- (c) Hydrogen
- (d) Nitrogen

Choose the correct answer from the options given below :

- (1) (b), (a), (c), (d)
- (2) (a), (b), (c), (d)
- (3) (c), (a), (b), (d)
- (4) (b), (c), (d), (a)

Ans. [2]

Sol. The arrangement of elements in descending order of their contribution to percentage weight of the human body is Oxygen (65%) → Carbon (18.5%) → Hydrogen (9.5%) → Nitrogen (3.3%)

Chapter : Chemical Coordination and Regulation

Q.131 Which one of the following statements is incorrect?

- (1) β -cells of pancreas secrete insulin
- (2) α -cells of pancreas secrete glucagon
- (3) α -cells of pancreas secrete insulin
- (4) Glucagon stimulates glycogenolysis

Ans. [3]

Sol. The two main types of cells in the Islet of Langerhans are called α -cells and β -cells.

The α -cells secrete a hormone called glucagon, while the β -cells secrete insulin.

Glucagon stimulates glycogenolysis while insulin stimulates glycogenesis.

Chapter : Morphology of Flowering Plants

Q.132 Which of the following are characteristic features of Solanaceae family?

- (a) Flowers are bisexual and actinomorphic
- (b) Calyx have five sepals and are united
- (c) Androecium have five stamens and are epipetalous
- (d) Ovary is inferior

Choose the correct answer from the options given below :

- (1) (b), (c) and (d) only
- (2) (a), (b) and (c) only
- (3) (d) only
- (4) (a) and (b) only

Ans. [2]

Sol. In Solanaceae family, flowers are bisexual and actinomorphic. Calyx include five sepals that are united.

Androecium include five stamens and it is epipetalous. Ovary is superior.

Chapter : Animal kingdom

Q.133 Given below are two statements :

Statement I : When any plane passing through the central axis of the body divides the organism into two identical halves, it is called radial symmetry.

Statement II : In phylum Echinodermata, both adults and larvae are radially symmetrical.

In the light of the above statements, choose the most appropriate answer from the options given below :

- (1) Statement I is incorrect but Statement II is correct
- (2) Both Statement I and Statement II are correct
- (3) Both Statement I and Statement II are incorrect
- (4) Statement I is correct but Statement II is incorrect

Ans. [4]

Sol. When any plane passing through the central axis of the body divides the organism into two identical halves, it is called radial symmetry. The members of the phylum Echinodermata exhibits radial or bilateral symmetry depending on the stage.

Adult echinoderms are radially symmetrical while larval echinoderms are bilaterally symmetrical.

Chapter : Cell Cycle and Cell Division

Q.134 The correct sequence of adult cell cycle phases is _____.

- (1) S-M-G₂-G₁
- (2) G₁-G₂-S-M
- (3) G₁-M-G₂-S
- (4) G₁-S-G₂-M

Ans. [4]

Sol. Gap₁ phase is the first phase of interphase. After Gap₁ phase, synthesis phase starts in which DNA replicates, then Gap₂ phase occur and finally cell cycle ends with M phase (mitosis).

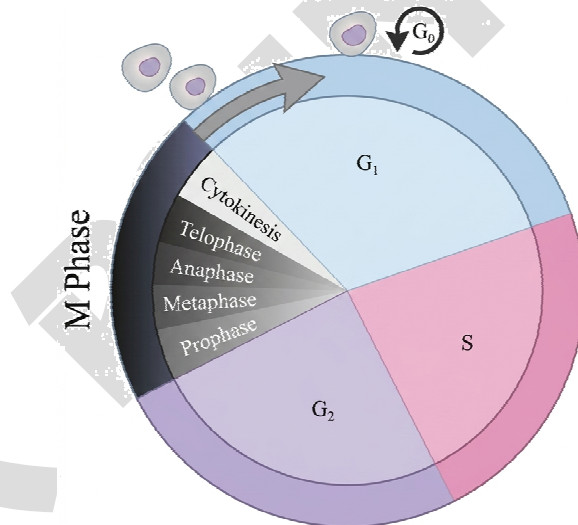

Chapter : STRUCTURAL ORGANISATION IN ANIMALS (Lower Animals)

Q.135 In frogs, the number of pairs of cranial nerves arising from the brain are _____.

- (1) 12
- (2) 6
- (3) 9
- (4) 10

Ans. [4]

Sol. In frogs, there are ten pairs of cranial nerves arising from the brain.

Chapter : Biotechnology : Principles and Processes

Q.136 Given below are two statements : one is labelled as Assertion A and the other is labelled as Reason R.

Assertion A : In recombinant DNA technology, lysozyme is used for disrupting bacterial cells while cellulose is for plant cells.

Reason R : Isolation of genetic material needs disruption of cells.

In the light of the above statements, choose the most appropriate answer from the options given below :

- (1) A is not correct but R is correct
- (2) Both A and R are correct and R is the correct explanation of A
- (3) Both A and R are correct but R is not the correct explanation of A
- (4) A is correct but R is not correct

Ans. [2]

Sol. Since, the DNA is enclosed within the membranes, we have to break the cell open to release DNA along with other macromolecules such as RNA, proteins, polysaccharides and also lipids. This can be achieved by treating the bacterial cells/plant or animal tissue with enzymes such as lysozyme (bacteria), cellulase (plant cells), chitinase (fungus).

Chapter : Reproductive Health

Q.137 The method of directly of injecting a sperm into ovum in assisted reproductive technology is called :

- (1) Embryo transfer (ET)
- (2) Gamete intra fallopian transfer (GIFT)
- (3) Zygote intra fallopian transfer (ZIFT)
- (4) Intra cytoplasmic sperm injection (ICSI)

Ans. [4]

Sol. Intra cytoplasmic sperm injection (ICSI) is a procedure to form an embryo in the laboratory in which a sperm is directly injected into the ovum.

ZIFT (Zygote intra fallopian transfer) involves transfer of the zygote or early embryos with upto 8 blastomeres into the fallopian tube.

GIFT (Gamete intra fallopian transfer) involves transfer of an ovum collected from a donor into the fallopian tube of another female who cannot produce one, but can provide suitable environment for fertilisation and further development.

Chapter : Evolution

Q.138 Adaptive radiation in placental mammals and Australian Marsupials leading to similarity between distant species is an example of _____.

- (1) genetic drift
- (2) divergent evolution
- (3) convergent evolution
- (4) founder effect

Ans. [3]

Sol. When more than one adaptive radiation appeared to have occurred in an isolated geographical area (representing different habitats), one can call this convergent evolution.

Placental mammals in Australia also exhibit adaptive radiation in evolving into varieties of such placental mammals each of which appears to be 'similar' to a corresponding marsupial.

Chapter : Principle of Inheritance and Variation

Q.139 Given below are two statements : one is labelled as Assertion A and the other is labelled as Reason R.

Assertion A : In an experiment, Mendel observed that the F_1 progeny plants are all tall and none are dwarf.

Reason R : Stem height is a contrasting trait, with tall being dominant and dwarf being recessive.

In the light of the above statements, choose the most appropriate answer from the options given below :

- (1) A is not correct but R is correct
- (2) Both A and R are correct and R is the correct explanation of A
- (3) Both A and R are correct but R is not the correct explanation of A
- (4) A is correct but R is not correct

Ans.[2]

Sol. Mendel crossed tall and dwarf plants and observed that all the F_1 progeny plants are tall.

The trait 'T' or tall is said to be dominant over the other allele 't' or 'dwarf' trait.

It is thus due to this dominance of one trait over the other that all the F_1 are tall.

Chapter : Biodiversity and Its Conservation

Q.140 Arrange the following in descending order of number of species in the Amazonian rain forest.

- Plants
- Birds
- Fishes
- Invertebrates
- Mammals

Choose the correct answer from the options given below :

- (b) > (a) > (d) > (c) > (e)
- (c) > (b) > (d) > (e) > (a)
- (d) > (a) > (c) > (b) > (e)
- (e) > (b) > (a) > (c) > (d)

Ans. [3]

Sol. The Amazonian rain forest is home to more than 40,000 species of plants, 3,000 of fishes, 1300 of birds, 427 of mammals, 378 of reptiles and of more than 1,25,000 invertebrates.

Hence the correct decreasing order would be (d) > (a) > (c) > (b) > (e)

Chapter : Animal kingdom

Q.141 Sponges exchange O₂ with CO₂ by _____.

- gills
- simple diffusion over their entire body surfaces
- moist cuticle
- tracheal tubes

Ans. [2]

Sol. Mechanisms of breathing vary among different groups of animals depending mainly on their habitats and levels of organisation.

Lower invertebrates like sponges, coelenterates, flatworms, etc., exchange O₂ with CO₂ by simple diffusion over their entire body surfaces. Earthworms use their moist cuticle and insects have a network of tubes (tracheal tubes) to transport atmospheric air within the body.

Gills are used by most of the aquatic arthropods and molluscs.

Chapter : Principle of Inheritance and Variation

Q.142 For a person with blood group 'O', which of the following is not a possible combination of parents' blood group genotypes?

- Father : I^AI^B and Mother : I^Ai
- Father : I^Ai and Mother : I^Bi
- Father : I^Ai and Mother : I^Ai
- Father : I^Bi and Mother : I^Bi

Ans. [1]

Sol. When I^A and I^B are present together they both express their own type of sugars.

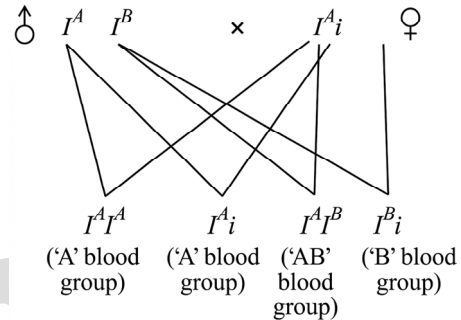

This combination of parent blood group are not possible for a person with blood group 'O'.

For a child to have type 'O' blood, both biological parents must carry the recessive 'O' allele and pass it down.

Chapter : Evolution

Q.143 Given below are two statements :

Statement I : Modern *Homo sapiens* arose in Australia and moved across continents.

Statement II : *Homo sapiens* arose around 75000 to 10000 years ago.

In the light of the above statements, choose the most appropriate answer from the options given below :

- Statement I is incorrect but Statement II is correct
- Both Statement I and Statement II are correct
- Both Statement I and Statement II are incorrect
- Statement I is correct but Statement II is incorrect

Ans. [1]

Sol. *Homo sapiens* arose in Africa and moved across continents and developed into distinct races.

During ice age, between 75,000 – 10,000 years ago, modern *Homo sapiens* arose.

Chapter : Human Health and Disease

Q.144 Which of the following is used as an effective sedative and painkiller for treating post-surgery patients?

- (1) Anti-retroviral drugs
- (2) Interferon
- (3) Antibiotics
- (4) Morphine

Ans. [4]

Sol. Morphine is a very effective sedative and painkiller and is very useful in patients who have undergone surgery.

Interferon belongs to cytokine barrier of innate immunity.

Antibiotics are used for restricting the growth of bacteria.

Chapter : Sexual Reproduction in Flowering Plants

Q.145 Which of the following plant produces non-albuminous seeds?

- (1) Pea
- (2) Wheat
- (3) Maize
- (4) Barley

Ans. [1]

Sol. Non-albuminous seeds have no residual endosperm as it is completely consumed during embryo development. E.g. Pea.

Wheat, maize and barley are the examples of albuminous seeds.

Chapter : Organism and Populations

Q.146 Given below are two statements : one is labelled as Assertion A and the other is labelled as Reason R.

Assertion A : Abingdon tortoise in Galapagos islands became extinct within a decade after goats were introduced.

Reason R : Goats were more efficient at browsing than Abingdon tortoise.

In the light of the above statements, choose the most appropriate answer from the options given below:

- (1) A is not correct but R is correct
- (2) Both A and R are correct and R is the correct explanation of A
- (3) Both A and R are correct but R is not the correct explanation of A
- (4) A is correct but R is not correct

Ans. [2]

Sol. Abingdon tortoise in Galapagos islands became extinct within a decade after goats were introduced on the island, apparently due to the greater browsing efficiency of the goats.

Chapter : Human Reproduction

Q.147 The covering of ovum at ovulation is _____.

- (1) chorion
- (2) endometrium
- (3) zona radiata
- (4) zona pellucida

Ans. [4]

Sol. The Graafian follicle ruptures to release the secondary oocyte (ovum) from the ovary by the process called ovulation.

The secondary oocyte forms a membrane called zona pellucida surrounding it.

Endometrium is the innermost layer of uterine wall.

Chorion is the outermost extraembryonic membrane that surrounds the embryo.

Chapter : Human Health and Disease

Q.148 Which of the following is used as a clot buster?

- (1) Statins
- (2) Streptokinase
- (3) Penicillin
- (4) Cyclosporin A

Ans. [2]

Sol. Streptokinase produced by the bacterium *Streptococcus* and modified by genetic engineering is used as a 'clot-buster' for removing clots from the blood vessels of patients who have undergone myocardial infarction leading to heart attack.

Chapter : Human Reproduction

Q.149 Which of the following structure is not a part of the male reproductive system?

- (1) Infundibulum
- (2) Rete testis
- (3) Epididymis
- (4) Vasa efferentia

Ans. [1]

Sol. The male sex accessory ducts include rete testis, vasa efferentia, epididymis and vas deferens.

The oviducts, uterus and vagina constitute the female accessory ducts.

Infundibulum is the part of oviduct.

Chapter : Human Reproduction

Q.150 Given below are two statements:

Statement I : Ovulation is caused by LH surge leading to rupture of Graafian follicles.

Statement II: Graafian follicle remaining after ovulation transform into corpus luteum and secretes large amount of estrogen.

In the light of the above statements, choose the most appropriate answer from the options given below:

- (1) Statement I is incorrect but Statement II is correct
- (2) Both Statement I and Statement II are correct
- (3) Both Statement I and Statement II are incorrect
- (4) Statement I is correct but Statement II is incorrect

Ans. [4]

Sol. Rapid secretion of LH leading to its maximum level during the mid-cycle called LH surge induces rupture of Graafian follicle and thereby the release of ovum (ovulation).

The remaining parts of the Graafian follicle transform as the corpus luteum, which secretes large amounts of progesterone.

Chapter : Body Fluids and Circulation

Q.151 The opening between the right atrium and the right ventricle is guarded by

- (1) sino-atrial node (2) bicuspid valve
- (3) tricuspid valve (4) semilunar valve

Ans. [3]

Sol. The opening between the right atrium and the right ventricle is guarded by a valve formed of three muscular flaps or cusps, called the tricuspid valve.

A bicuspid/mitral valve guards the opening between the left atrium and the left ventricle.

The openings of the right and the left ventricles into the pulmonary artery and the aorta, respectively, are provided with the semilunar valves.

Chapter : Evolution

Q.152 Which of the following is not evidence for evolution ?

- (1) Divergent evolution of anatomical structures such as forelimbs
- (2) Convergent evolution of traits like wings of birds and butterflies
- (3) Paleontological evidence from fossil records
- (4) Embryological support for evolution as proposed by Ernst Haeckel

Ans. [2,4]

Sol. Divergent evolution of anatomical structures, such as forelimbs, indicate homology. Homology indicates common ancestry and acts as the evidence of evolution.

When same structure develops along different directions due to adaptation to different needs, they are called homologous structures.

Convergent evolution does not act as the evidence for evolution, because species can develop similar features without a common ancestor.

Fossils are remains of hard parts of life-forms found in rocks.

A study of fossils in different sedimentary layers indicates the geological period in which they existed.

Embryological support for evolution was proposed by Ernst Haeckel based upon the observation of certain features during embryonic stage common to all vertebrates that are absent in adult. But later, this proposal was disapproved on careful study performed by Karl Ernst von Baer.

Chapter : Biotechnology and Its Applications

Q.153 The inactive form of Bt toxin is converted to the active form in the insect gut

- (1) by nucleases
- (2) due to alkaline pH
- (3) due to acidic pH
- (4) by proteases

Ans. [2]

Sol. Bt toxin protein exists as inactive protoxins, but once an insect ingests the inactive toxin, it is converted into an active form of toxin due to the alkaline pH of the gut which solubilises the crystals.

Chapter : Evolution

Q.159 A population of diploid organisms is at Hardy-Weinberg equilibrium. If the frequency of allele A is 0.1, the frequency of AA is _____.

- (1) 0.99 (2) 0.01
(3) 0.02 (4) 0.10

Ans. [2]

Sol. The frequency of allele A(p) = 0.1
As per the Hardy-Weinberg equilibrium,
Frequency of AA = $p^2 = (0.1)^2 = 0.01$

Chapter : Human Reproduction

Q.160 Sperm motility is due to _____.

- (1) muscular movement
(2) flagellar movement
(3) ciliary movement
(4) amoeboid movement

Ans. [2]

Sol. Sperm travels across the fallopian tube *via* flagellar movement.

Chapter : Organism and Populations

Q.161 Consider a population of 10 million cells. Given the per-capita birth rate of 0.002 (per unit time) and the percapita death rate of 0.002 (per unit time), the expected number of cells after 10 generations is _____.

- (1) 100 million (2) 1 million
(3) 5 million (4) 10 million

Ans. [4]

Sol. The per-capita birth rate of bacteria is 0.002.
The per-capita death rate of bacteria is 0.002.
The population dynamic equation is

$$\frac{dN}{dt} = (b - d)N$$

$$\text{Since } r = (b - d) = 0.002 - 0.002 = 0$$

$$\frac{dN}{dt} = 0$$

So, the population remains constant at all times.
Thus, even after 10 generations, the expected number of cells will be 10 million.

Chapter : Evolution

Q.162 Given below are two statements : one is labelled as **Assertion A** and the other is labelled as **Reason R**.

Assertion A : Forelimbs of human and bats are homologous.

Reason R : Forelimbs of humans and bats have similar anatomical structure.

In the light of the above statements, choose the most appropriate answer from the options given below.

- (1) **A** is false but **R** is true
(2) Both **A** and **R** are correct and **R** is the correct explanation of **A**
(3) Both **A** and **R** are true, but **R** is not the correct explanation of **A**
(4) **A** is true but **R** is false

Ans. [2]

Sol. Forelimbs of bats and humans share similarities in the pattern of bone arrangement.

Though their forelimbs perform different functions, they have similar anatomical structure, as all of them have humerus, radius, ulna, carpals, metacarpals and phalanges in their forelimbs.

Hence, in these animals, the same structure developed along different directions due to adaptation to different needs. This is divergent evolution, and these structures are homologous.

Chapter : Locomotion and Movement

Q.163 Muscle contraction is initiated by a signal sent by the central nervous system by the release of _____.

- (1) cyclic adenine monophosphate
(2) acetyl choline
(3) acetyl coenzyme A
(4) cyclic guanine monophosphate

Ans. [2]

Sol. Muscle contraction is initiated by a signal sent by the central nervous system (CNS) *via* a motor neuron.

The junction between a motor neuron and the sarcolemma of the muscle fibre is called the neuromuscular junction or motor-end plate. A neural signal reaching this junction releases a neurotransmitter (Acetylcholine) which generates an action potential in the sarcolemma.

Chapter : Human Reproduction

Q.164 Which of the following hormone is not secreted by human placenta?

- (1) LH (2) hCG
(3) Estrogen (4) Progesterone

Ans. [1]

Sol. The placenta acts as a temporary endocrine gland during pregnancy, secreting several vital hormones essential for fetal development and maintenance of pregnancy.

Several hormones produced by placenta are human chorionic gonadotropin (hCG), human placental lactogen (hPL), estrogen, progesterone, etc.

Luteinizing hormone (LH) is secreted by anterior pituitary.

Chapter : Human Health and Disease

Q.165 Which of the following statements is correct about *Plasmodium*?

- (1) Fertilization takes place in mosquito gut
(2) Reproduces sexually in liver cells
(3) Reproduces sexually in RBCs
(4) Gametocytes develop in mosquito gut

Ans. [1]

Sol. *Plasmodium* reproduces asexually in liver cells. *Plasmodium* parasite reproduce asexually in red blood cells, bursting the RBCs and causing cycles of fever and other symptoms. Released parasites infect new red blood cell. Female *anopheles* mosquito takes up gametocytes with blood meal.

Fertilization and development take place in the mosquito's gut.

Sexual stages of *plasmodium* (gametocytes) develop in RBC.

Chapter : Ecosystem

Q.166 Which of the following are primary consumers in a food chain?

- (1) Carnivores (2) Parasites
(3) Predators (4) Herbivores

Ans. [4]

Sol. Primary consumers in a food chain are the herbivores.

Chapter : Excretory Products and Their Elimination

Q.167 Which of the following statements about the reabsorption process in Henle's loop are correct?

- (a) The descending limb of Henle's loop is permeable to water but almost impermeable to electrolytes.
(b) Urine gets concentrated in Henle's loop.
(c) Reabsorption of Na⁺ and water takes place in Henle's loop.
(d) Active or passive transport of electrolytes occurs in the ascending limb of Henle's loop.

Choose the correct answer from the options given below:

- (1) (a), (b) and (d) only
(2) (a) and (b) only
(3) (b), (c) and (d) only
(4) (a), (b) and (c) only

Ans. [*]

Sol. None of the given options are correct

Chapter : Organism and Populations

Q.168 Given below are two statements : one is labelled as **Assertion A** and the other is labelled as **Reason R**.

Assertion A : The logistic growth model of populations is considered more realistic than the exponential growth model.

Reason R : Resources are finite.

In the light of the above statements, choose the most appropriate answer from the options given below :

- (1) **A** is not correct but **R** is correct
(2) Both **A** and **R** are correct and **R** is the correct explanation of **A**
(3) Both **A** and **R** are correct but **R** is not the correct explanation of **A**
(4) **A** is correct but **R** is not correct

Ans. [2]

Sol. The logistic growth model of populations is considered more realistic than the exponential growth model because resources are limited/finite in nature.

Chapter : Locomotion and Movement

Q.169 Which of the following is the correct order of arrangement of vertebrate column from the head to toe?

- (1) Cervical vertebra, thoracic vertebra, lumbar vertebra, sacrum
- (2) Cervical vertebra, thoracic vertebra, sacrum, lumbar vertebra
- (3) Sacrum, lumbar vertebra, thoracic vertebra, cervical vertebra
- (4) Cervical vertebra, lumbar vertebra, thoracic vertebra, sacrum

Ans. [1]

Sol. The vertebral column is formed by 26 serially arranged units called vertebrae and is dorsally placed.

The vertebral column is differentiated into cervical (7), thoracic (12), lumbar (5), sacral (1-fused) and coccygeal (1-fused) regions starting from the skull.

So, the correct sequence will be : Cervical, thoracic, lumbar, sacrum and coccyx.

Chapter : Organism and Populations

Q.170 Match List-I with List-II.

List-I		List-II	
A.	Both species are harmed	I.	Predation
B.	One species is harmed and the other is benefited	II.	Mutualism
C.	Both species are benefited	III.	Competition
D.	One is benefited while the other has no effect	IV.	Commensalism

Choose the **correct** answer from the options given below:

- (1) A-III, B-I, C-II, D-IV
- (2) A-III, B-IV, C-II, D-I
- (3) A-I, B-II, C-III, D-IV
- (4) A-II, B-I, C-IV, D-III

Ans. [1]

Sol. Both species are harmed in competition.
One species is harmed and the other is benefited in predation.
Both species are benefited in mutualism.
One species is benefited while the other has no effect in commensalism.

Chapter : Sexual Reproduction in Flowering Plants

Q.171 If the diploid chromosome number of typical angiosperm is 36, what would be the chromosome number in its endosperm?

- (1) 72
- (2) 18
- (3) 36
- (4) 54

Ans. [4]

Sol. The endosperm is triploid, if the diploid chromosome number of typical angiosperm is 36

$$\text{i.e. } 2n = 36 \text{ then } n = 18$$

$$\text{So, } 3n = n + n + n$$

$$= 18 + 18 + 18$$

$$= 54$$

Chapter : Molecular Basis of Inheritance

Q.172 Which of the following enzymes synthesizes precursor mRNA?

- (1) DNA polymerase
- (2) RNA polymerase I
- (3) RNA polymerase II
- (4) RNA polymerase III

Ans. [3]

Sol. The RNA polymerase II transcribes precursor of mRNA, the heterogeneous nuclear RNA (hnRNA)

Chapter : Biotechnology : Principles and Processes

Q.173 Given below are two statements :

Statement I : Plasmids are autonomously replicating DNA.

Statement II : Plasmids are extrachromosomal DNA.

In the light of the above statements, choose the most appropriate answer from the options given below :

- (1) **Statement I** is incorrect but **Statement II** is correct
- (2) Both **Statement I** and **Statement II** are correct
- (3) Both **Statement I** and **Statement II** are incorrect
- (4) **Statement I** is correct but **Statement II** is incorrect

Chapter : Human Health and Disease

Q.178 Which of the following are secondary lymphoid organs?

- (a) Bone marrow (b) Tonsils
(c) Spleen (d) Thymus

Choose the correct answer from the options given below:

- (1) (a) and (d) only (2) (a) and (b) only
(3) (b) and (c) only (4) (b) and (d) only

Ans. [3]

Sol. Bone marrow and thymus are primary lymphoid organs while tonsils, spleen are secondary lymphoid organs.

Chapter : Biotechnology : Principles and Processes

Q.179 During PCR, primers bind to the DNA strands in the _____ step.

- (1) ligation (2) denaturation
(3) extension (4) annealing

Ans. [4]

Sol. PCR involves three steps, *i.e.* denaturation, annealing and extension.

During PCR, primers bind to the DNA strands in the annealing step.

Chapter : Principle of Inheritance and Variation

Q.180 Given below are two statements :

Statement I : Down's syndrome is caused by the absence of one of the X-chromosomes.

Statement II : Turner's syndrome is caused by the presence of an additional copy of the chromosomes.

In the light of the above statements, choose the correct answer from the options given below :

- (1) **Statement I** is incorrect but **Statement II** is correct
(2) Both **Statement I** and **Statement II** are correct
(3) Both **Statement I** and **Statement II** are incorrect
(4) **Statement I** is correct but **Statement II** is incorrect

Ans. [3]

Sol. The cause of genetic disorder-Down's syndrome is the presence of an additional copy of the chromosome number 21 (Trisomy 21).

The cause of genetic disorder-Turner's syndrome is the absence of one of the X-chromosomes; *i.e.* 45 with X_0 .